



FLANGE IN ALLUMINIO

Per rulli D.76 e 89 sono previste flange in alluminio fornite separatamente in un unico kit, costituito da due elementi completo di bulloni di fissaggio zincati, per consentire di posizionarle a piacere.

Attenzione:

le viti vanno serrate con chiave dinamometrica con coppia ≤ 13 Nm.

Esempio descrizione:

Flange D.89/150 alluminio kit 3018010900

ALUMINIUM FLANGES

For the rollers diameter 76 and 89 mm, aluminium flanges are supplied separately in a special kit, composed by 2 elements and complete with zinc plated fixing bolts to assemble them in different ways.

Attention:

the screws must be tightened by torque wrench ≤ 13 Nm.

Description example:

Flanges D.89/150 aluminium kit 3018010900

Codice / Code	D	De	D1	Kit rif. - ref.	Peso compl. Total weight daN
SF_FLG.SPC-00004	76	130	90	3018010767	0,26
SF_FLG.SPC-00003	89	150	104	3018010900	0,28

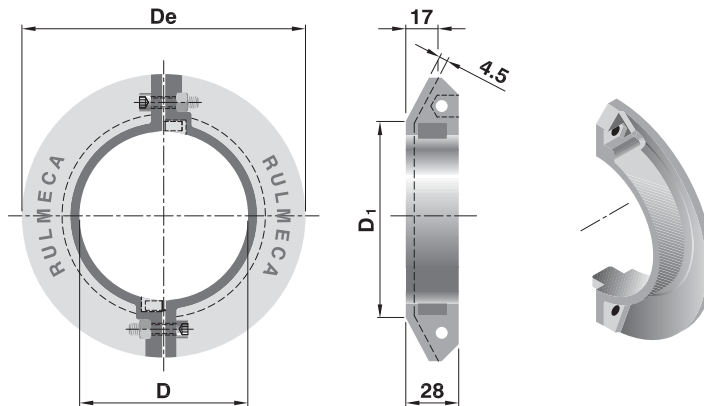

MANICOTTI DI MAGGIOR ATTRITO

Dove si rende necessario creare un attrito maggiore tra i rulli e i colli trasportati è particolarmente efficace l'applicazione di questi manicotti. Sono realizzati in Poliuretano 75 Sh.A trasparente a scanalatura longitudinale e vengono forniti sfusi, da montare per stretta interferenza solo su rulli con tubo $\varnothing 50$.

Codice: SVGN-00050

Descrizione: Manicotti D.45/55 L=35

Tutte le quote sono espresse in mm.

HIGH FRICTION SLEEVES

Where it is necessary to increase friction between the rollers and the handled unit loads the employment of these sleeves are particularly effective. They are made with transparent Polyurethane 75 Sh.A with longitudinal grooves and are supplied separately only for rollers with tube $\varnothing 50$.

Code: SVGN-00050

Description: Sleeves D.45/55 L=35

All dimensions are in mm.

