PROFILI PER TRASPORTATORI A GRAVITÀ

Tutti in lamiera zincata a caldo (sendzimir), questi profili sono previsti prevalentemente per l'impiego nei trasportatori a rulli con asse a molla o forato e filettato.

I tipi PR U50 sono ideali per trasportatori a più corsie o per guide di contenimento a rulli.

Tutti i profili sono da intestare per ottenere il primo foro con centro a 13 mm dall'estremità; pertanto i valori di lunghezza "L" sono puramente nominali.

PROFILES FOR GRAVITY CONVEYORS

All hot zinc-plated (sendzimir), these profiles are generally employed in spring-loaded or internally threaded shaft idler roller conveyor applications.

The PR U50 type are ideal for conveyor systems with multiple rows or as roller side frames.

All the profiles are cut to obtain the first hole with a 13 mm pitch from the end, consequently "L" length values are merely nominal.

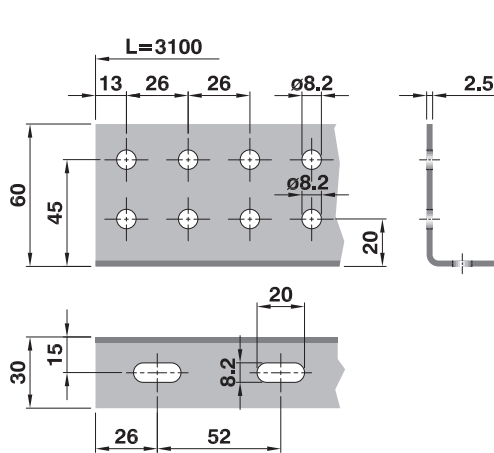

Profilo-Profile
PR L60 3100
 Peso-Weight = 4,60 daN

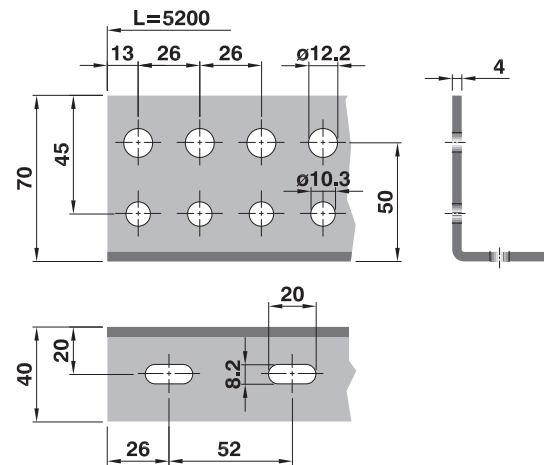

Profilo-Profile
PR L70 5200
 Peso-Weight = 14,80 daN

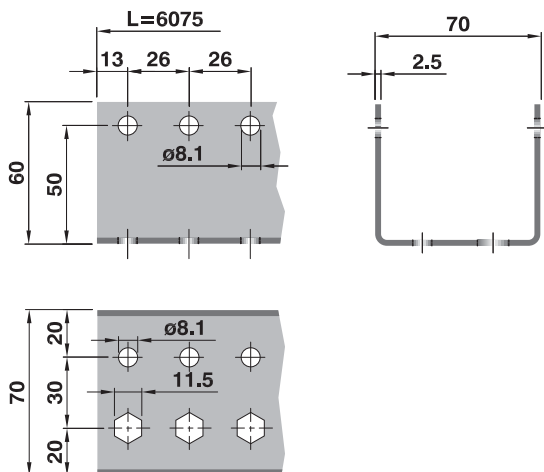

Profilo-Profile
PR U50 6075
 Peso-Weight = 19,80 daN

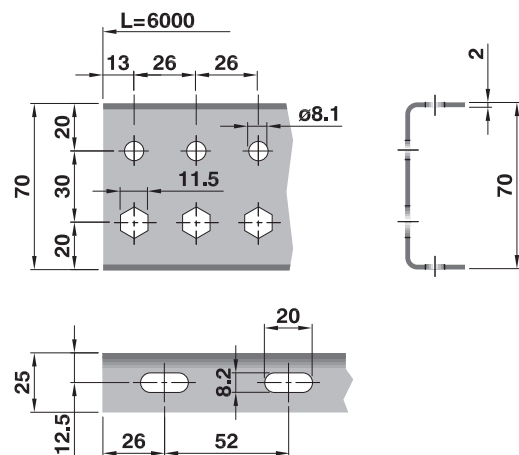

Profilo-Profile
PR C70 6000
 Peso-Weight = 9,70 daN

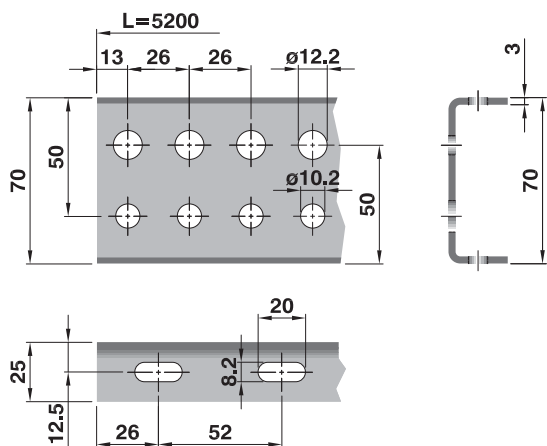

Profilo-Profile
PR C72 5200
Peso-Weight = 11,60 daN

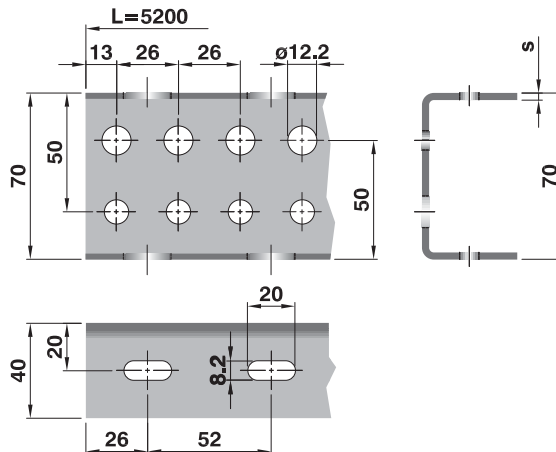

Profilo-Profile
PR C73 5200 s=3 Peso-Weight = 15,20 daN
PR C74 5200 s=4 Peso-Weight = 20,30 daN

CAPACITÀ DI CARICO

Nel diagramma rappresentato si possono rilevare i valori di carico ammissibili dei profili presentati. Tali valori sono variabili in relazione alla distanza "L" fra gli appoggi, validi per un'inflessione massima di $f=2$ mm., avendo considerato la sollecitazione e fatica.

LOAD CAPACITY

In the diagram, we show the admissible load capacity values of our profiles. Such values are variable in relation to the "L" distance between the supports, valid for a max. inflection of $f=2$ mm, considering the fatigue stress.

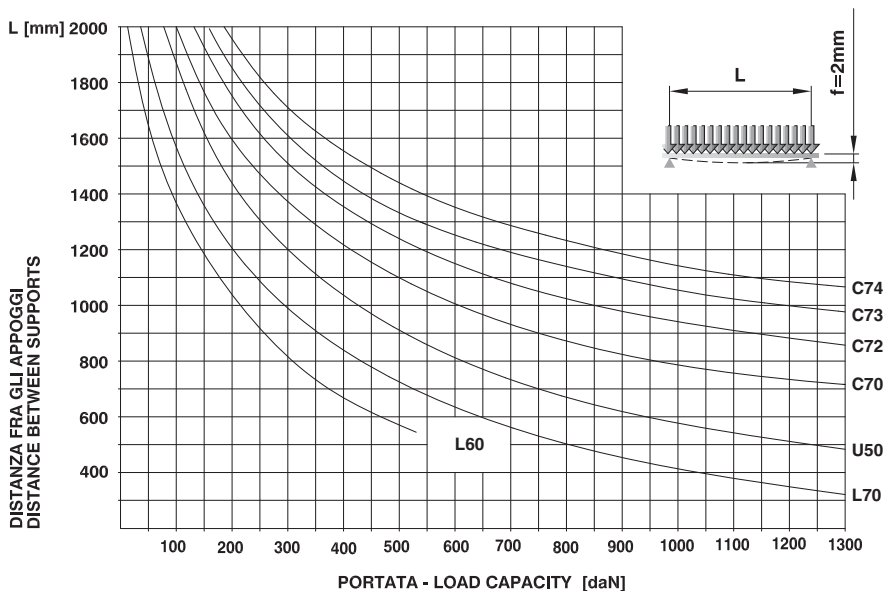

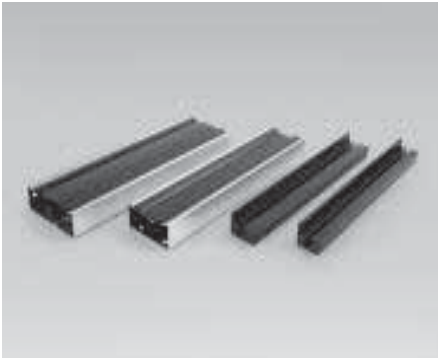

PROFILI PER TRASPORTATORI COMANDATI

I profili tipo CP1 e CP2 possono essere forniti grezzi o con zincatura elettrolitica. In abbinamento con i profili P5 e P6 carter in PVC grigio e i tappi di chiusura in Polietilene nero. Sono particolarmente adatti per realizzare trasportatori a rulli comandati e frizionati delle serie 135 e 138, con catena tangenziale oppure con trasmissione a cinghie.

Tutti i profili sono da intestare per ottenere il primo foro con centro a 13 mm dall'estremità; pertanto i valori di lunghezza "L" sono puramente nominali.

PROFILES FOR DRIVEN CONVEYORS

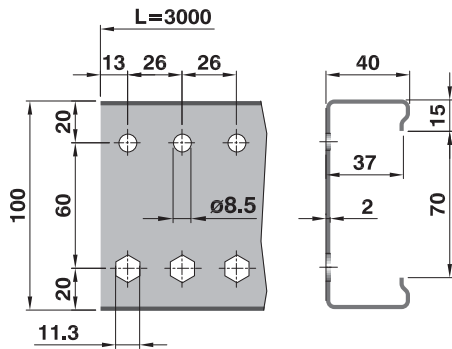
The CP1 and CP2 profiles can be supplied in a rough or in a galvanised version. Combined with the P5 and P6 profiles, grey PVC cover strip and black Polyethylene end caps. They are particularly suited to build conveyors with motorized and friction rollers series 135 and 138, with tangential chain or belt transmission. All the profiles are cut to obtain the first hole with a 13 mm pitch from the end, consequently "L" length values are merely nominal.



Profilo-Profile
 PR CP1 3000 (Grezzo-Rough)
 PR CP1J 3000 (Zincato-Galvanized)
 Peso-Weight = 9,50 daN

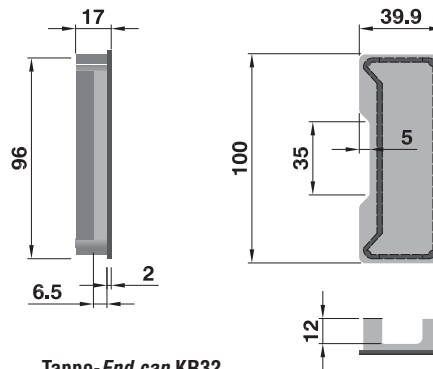

Tappo-End cap KR32
 Code RMSP-00138
 Peso-Weight = 0,012 daN

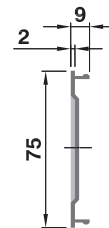

Carter-Cover strip L3000
 PR P5 3000
 Peso-Weight = 0,75 daN

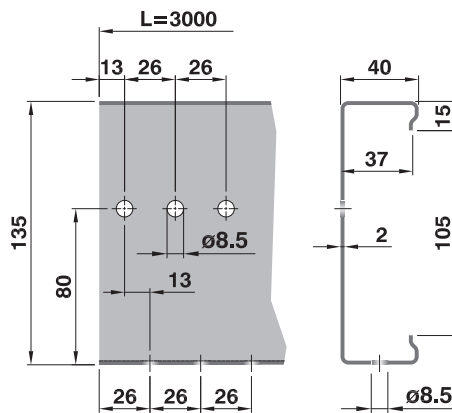

Profilo-Profile
 PR CP2 3000 (Grezzo-Rough)
 PR CP2J 3000 (Zincato-Galvanized)
 Peso-Weight = 11,00 daN

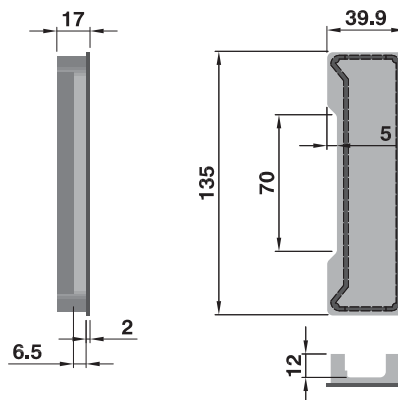

Tappo-End cap KR31
 Code RMSP-00137
 Peso-Weight = 0,017 daN

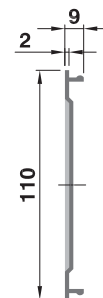

Carter - cover strip L3000
 PR P6 3000
 Peso-Weight = 0,75 daN

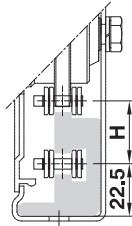

Profilo guidacatena - Lunghezza L=2000
Chain guide profile - Length L=2000

Codice profilo guidacatena Chain guide profile code	Pignone Sprocket	H	Peso Weight daN
RMSP-00135	1/2' Z=14	27	1,52
RMSP-00136	1/2' Z=11	33	1,70
RMSP-00134	1/2' Z=9	37	1,90

PORTATA DEI PROFILI

Valori validi per inflessione max. $f=2\text{mm}$

LOAD CAPACITY OF PROFILES

valid values for a max. inflection $f = 2\text{ mm}$

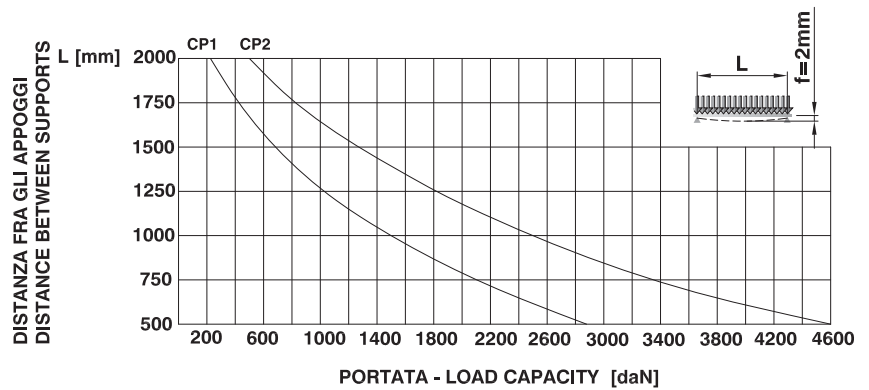

ESEMPIO DI APPLICAZIONE CON TRASMISSIONE A CATENA APPLICATION EXAMPLE WITH CHAIN TRANSMISSION

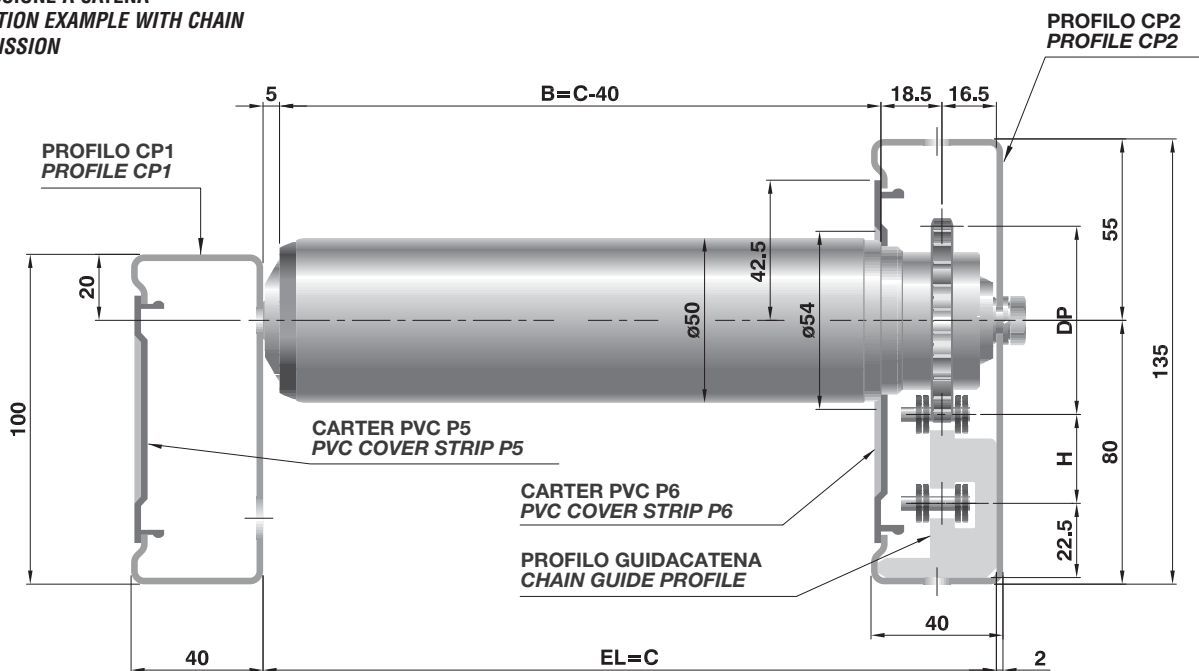

SUPPORTI

Sono elementi di sostegno dei rulli sia folli che comandati, da saldare o imbullonare alle spalle della struttura portante.

I tipi della serie 700 possono essere saldati, mentre il fissaggio con viti consente di correggere errori di parallelismo e ortogonalità.

SUPPORTS

Supporting elements for gravity and driven rollers to be welded or bolted to the supporting structure frames.

The series 700 types can be welded, while bolt fixing allows correction of any eventual parallelism and squareness mistakes.

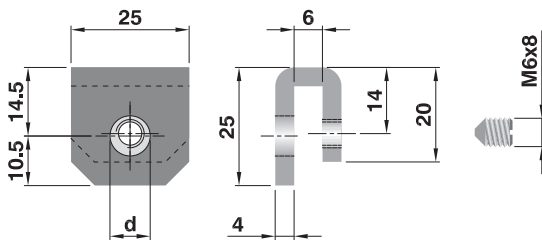

Tipo Type	d	r	Peso/Weight daN
SPT/3 281 F8	8,5	4	0,032
SPT/3 281 F10	10,5	5	0,030
SPT/3 281 F12	12,5	6	0,028

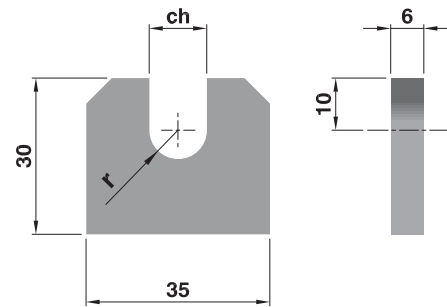

Tipo Type	ch	r	Peso/Weight daN
SPT 218 F8	8,5	4	0,047
SPT 218 F10	10,5	5	0,045
SPT 218 F12	12,5	6	0,042

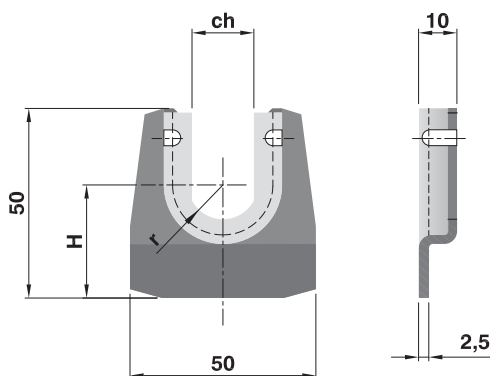

Tipo Type	d	H	r	Peso/Weight daN
SPT 500 F10	10,5	34	6	0,050
SPT 500 F12	12,5	32,5	7,5	0,051
SPT 500 F14	14,5	30	10	0,049
SPT 500 F17	17,5	30	10	0,047

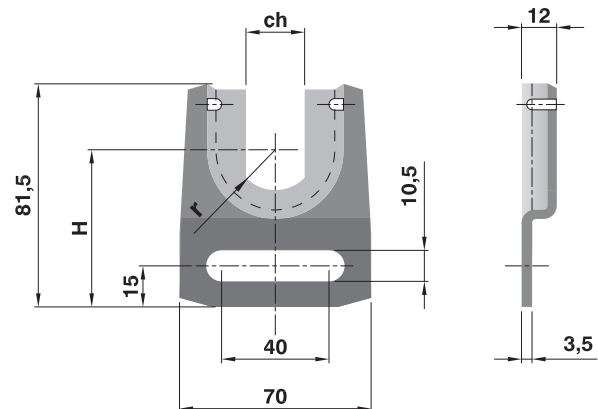

Tipo Type	ch	H	r	Peso/Weight daN
SPT 700 F14	14,5	62,5	10	0,141
SPT 700 F17	17,5	62,5	10	0,136
SPT 700 F18	18,5	60	12,5	0,135
SPT 700 F22	22,5	57,5	15	0,130