

2.5 - Programme

The experience of Rulmeca for over 50 years producing belt conveyor rollers, has perfected and expanded the range of products we offer, so that the user will find the correct answer to the most diverse and difficult applications,

This catalogue presents the different series of rollers in production and their relative utilisation criteria.

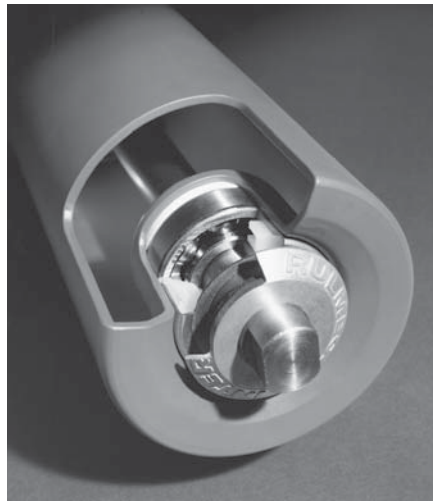

1



2

- 1 - Rollers in steel series PSV
- 2 - Rollers in plastic series PL
- 3 - Rollers in steel series MPS
- 4 - Rollers in thermoplastic polymer series TOP
- 5 - Rollers in steel series RTL

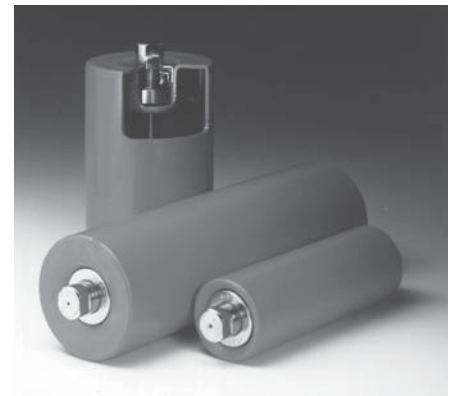

3



4



5



2 Rollers

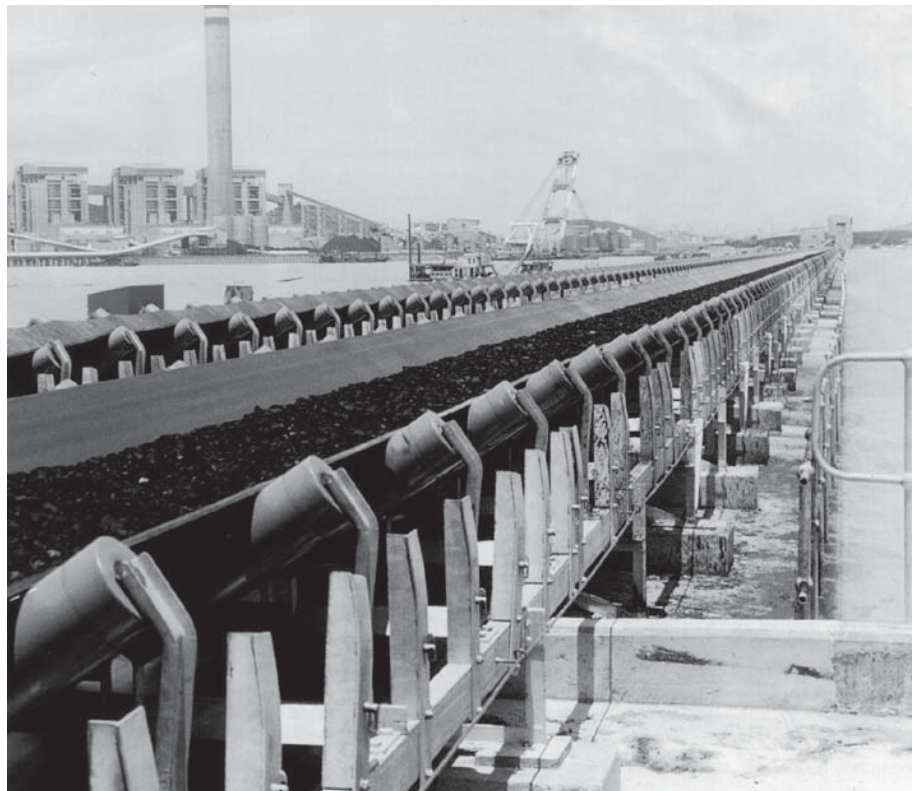

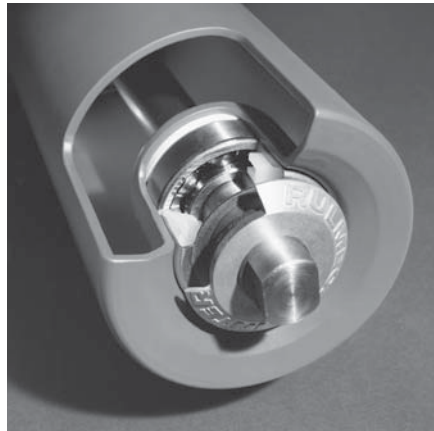

2.5.1 - Rollers series PSV

Where used

Rollers PSV are particularly suited to conveyors that operate in very difficult conditions, where working loads are high, and large lump size material is conveyed; and yet, despite these characteristics, they require minimal maintenance.

Typical types of application are: mines, caves, cement works, coal-fired electric utilities and dock installations.

The effectiveness of the PSV roller sealing system provides the solution to the environmental challenges of dust, dirt, water, low and high temperatures or applications where there is a large temperature imbalance between day and night.

The working temperature, with standard greased components is defined as between -20°C and $+100^{\circ}\text{C}$.

It is possible to reach temperatures outside of this range using special grease, bearings and seals.

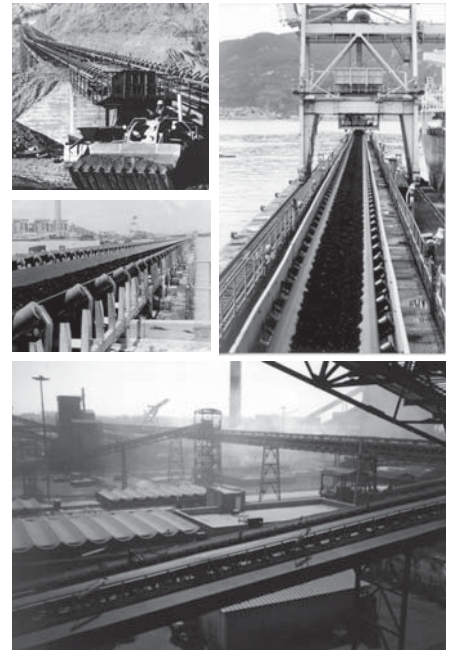



2 Rollers

series PSV

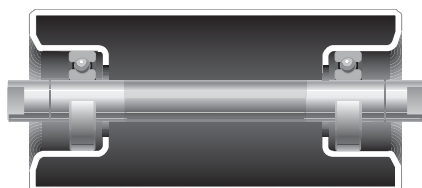

Monobloc



Spindle

Characteristics

The rollers series PSV offer the highest quality and the maximum load capacity of Rulmeca's production.

The unique design of our hermetic seal system not only protects the bearings but offers maximum effectiveness and long life, even in the presence of the most severe pollutants.

The control of all roller materials from incoming inspection, through manufacture and assembly in the automatic cycle, with on line function tests on 100% of production, allows us to state that the function and life of this roller is among the highest in the world.

Attention to detail, whether at the design stage or in the various manufacturing phases, observing close limits of starting resistance, of eccentricity and axial play, results in notable savings in energy and a reduction in maintenance over time.

These factors give rise to business economies, confidence and high productivity, objectives pursued by all users of belt conveyors.

The Quality System certified ISO 9001:2008 got from Rulmeca attest to their continuous quality standards, and their stated performance.

Roller shell

It is the external diameter of the roller that is in contact with the conveyor belt.

It consists of a steel welded tube produced according to Rulmeca standards, with reference to tight tolerances and particular specifications.

The tube is cut and machined using automatic numerically controlled machines, that guarantee and maintain the tolerances and the precision of the square cut.

Bearing housing

It is a steel monolithic structure, deep drawn and sized to a forced tolerance ISO M7 at the bearing position. This tolerance is necessary to guarantee the optimum assembly of the bearing by ensuring that it is square to the spindle of the roller.

The thickness of the housings is proportional to the spindle diameter and to the bearing type, with thicknesses that are up to 5 mm, to guarantee the maximum strength for each application, including the heaviest.

Monobloc

The bearing housings of the PSV rollers are welded to the tube body using autocentring automatic welding machines utilising a continuous wire feed: our patented system "UNIBLOC".

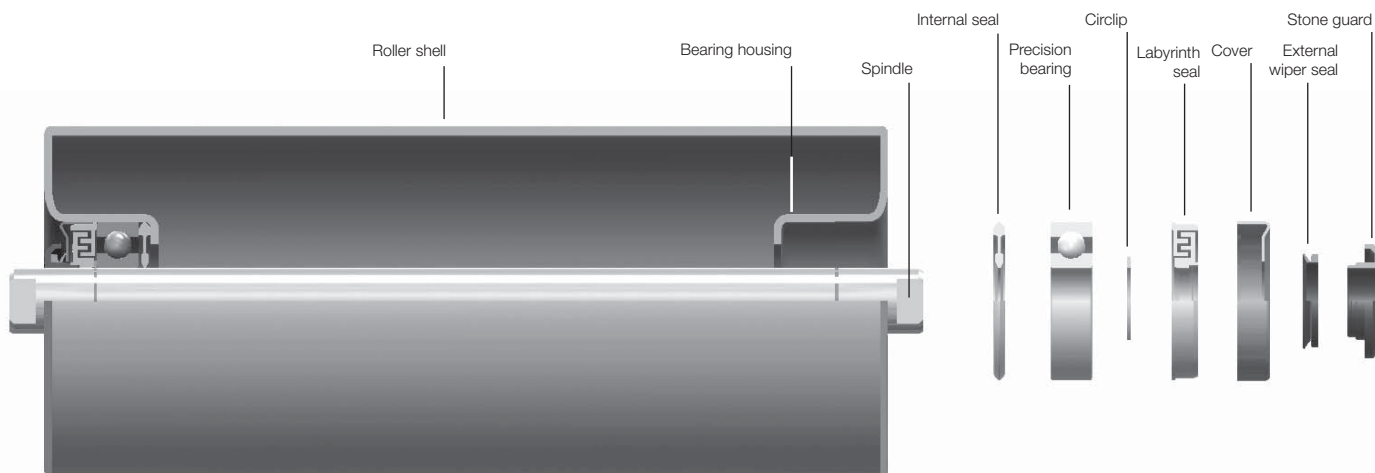

Section of PSV/1,2,3,4,5-FHD

Tube and bearing housing form a monolithic structure of exceptional strength which itself reduces to the minimum any imbalance in the roller. This guarantees the alignment and concentricity with respect to the external diameter of the component parts of the sealing system.

The optimum balance and concentricity thus obtained allows these rollers to be used at the highest speeds, eliminating harmful vibration to the conveyor structure and the “hammer effect” on the bearings of the rollers.

Spindle

This is the component which sustains the roller when it is assembled into the troughing set supports. It is made from drawn steel, cut and machined by automatic numerically controlled machines.

The spindle is ground for all its length or in the bearings and seals zones to a precision tolerance, to guarantee a perfect match of bearings, seals and optimum performance.

Bearings

These are the parts which give virtually frictionless rotation to the tube body with respect to the fixed spindle. Precision bearings only are used.

They are the radial ball race type of the series: 6204, 6205, 6305, 6206, 6306, 6308 with internal clearance tolerance C3, ideal for applications of rollers used for belt

conveyors.

Connecting spindle / bearing, bearing housing

PSV rollers require particular tolerances for the bearing housing, for the spindle and the bearing itself, that enables the roller to function optimally for a long life, whilst under pressure.

The above mentioned tolerances functionally guarantees the autoalignment of the internal and outer bearing rings of the ball race resulting in a good performance even when the spindle deflection is extreme due to overloading.

Sealing

The seals comprise the most important components in the design of the PSV rollers.

The principal task of the seals is to protect the bearing from harmful elements that may impinge from the outside or the inside of the roller.

The working conditions of these rollers is very often the most severe, with the presence of dust, abrasive sand, water and various other pollutants.

On the inside of the roller there may be particles formed by the rusting of the internal tube body or condensation caused by the thermal changes that arise between day and

night in particular climates.

The seal must also contain and retain a good quantity of grease for the bearing lubrication.

As a guarantee and to complete the PSV roller sealing system the final components are assembled at either end:

- strong external stone guards formed as a shield, in anti-corrosive thermoplastic material, to protect the seals from the fall of material onto the end cap of the roller.

- seal with two principal sections: one external and one internal.

- external section: self cleaning in that it centrifugally repels water and dust naturally towards the outside. Comprises a lip ring seal made from soft anti-abrasive rubber with a large contact surface that provides an effective hermetic seal of long working life. The self cleaning effect is principally due to the particular design of the cover cap and the shape of the bearing housing which when rotating, tends to expel all pollutants, centrifugally.

- internal section: triple lip labyrinth in nylon PA6 greased to give further bearing protection.

Behind the bearing a sealing ring in nylon PA6 is positioned that provides an ample

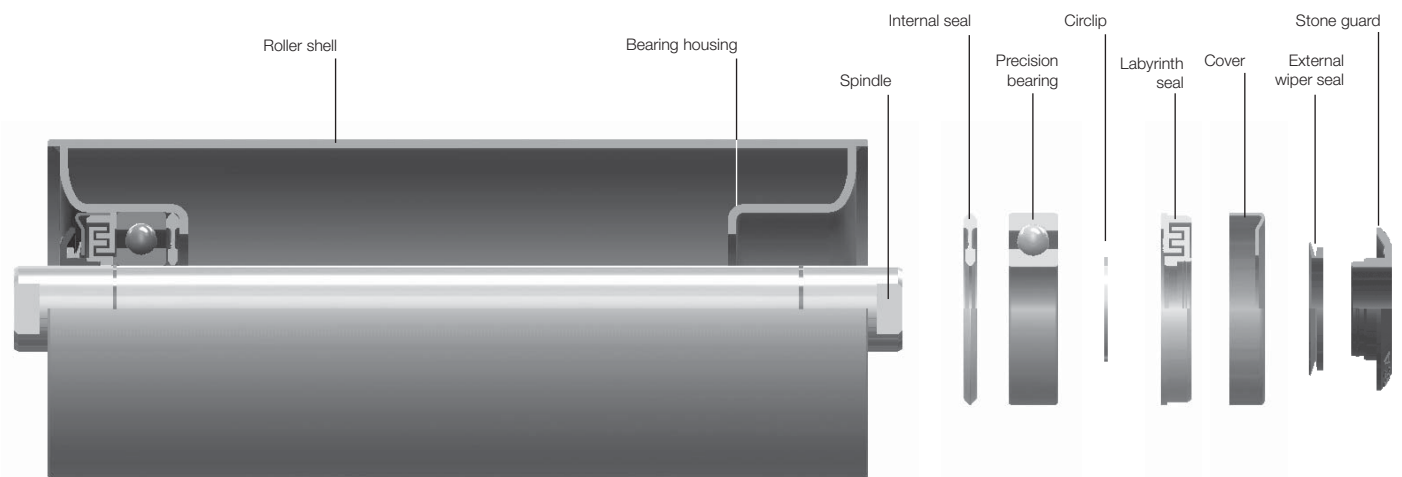

Section of PSV/7-FHD



2 Rollers

serie PSV

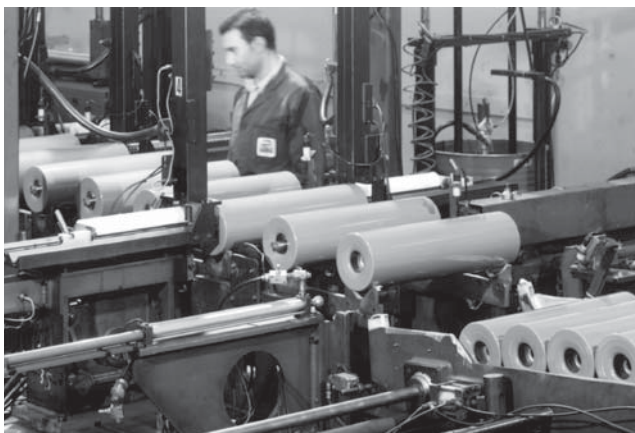

grease reservoir and also retains the grease near to the bearing even when there is a depression due to an abrupt change in temperature (pumping effect).

This ring acts also as a seal to counteract the eventual formation of condensation and oxidation which could take place inside the tube.

- locking system: provided by means of the correctly located circlips, which today is the best and the strongest system implemented in heavy rollers for belt conveyors.

Lubrication

PSV rollers are lubricated for life with an abundant quantity of lithium based water repellent grease, that guarantees the correct lubrication for the working life of the roller.

Final inspection

All PSV rollers are assembled on automatic assembly machines with live test stations that maintains roller rotation for a sufficient time to distribute the grease into the bearings and all the other internal components. 100% of the rollers are tested to verify their low-torque characteristics.

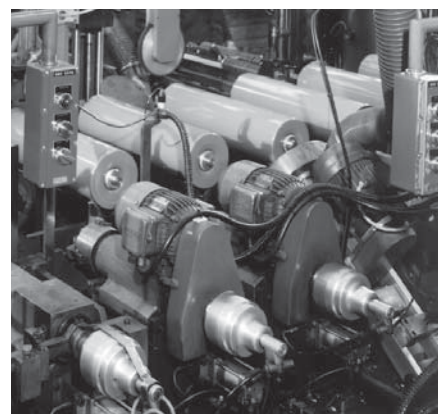

The table indicates the type and diameter of standard rollers in production according to European standards to DIN 15207- ISO 1537.

Upon request rollers may be supplied with varying dimensions, tube thickness end diameters according to standards CEMA, BS, JIS, AFNOR and FEM.



Rollers certified according to ATEX 94/9/EC norms, Explosion Group I category M2 for Mines, Explosion Group II category 2G for gas and 2D for dust, Explosion Group II category 3G for gas and 3D for dust (Zones 1, 2 for gas, Zones 21, 22 for dust).

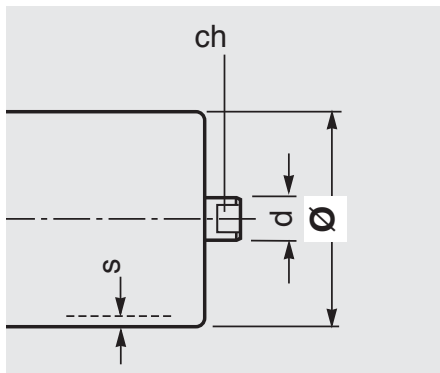

Programme of production series PSV

roller type	Ø mm	basic design	s	spindle d	ch	bearing	note
PSV/1-FHD	63	N	3	20	14	6204	with tube and spindle in steel S235JR (EN 10027-1) ex Fe360 (EN 10025), St37 (DIN 17100)
	89	N	3				
	108	N	3,5				
	133	N	4				
PSV/2-FHD	89	N	3	25	18	6205	
	108	N	3,5				
	133	N	4				
	159	N	4,5				
PSV/3-FHD	89	N	3	25	18	6305	
	108	N	3,5				
	133	N	4				
	159	N	4,5				
PSV/4-FHD	89	N	3	30	22	6206	
	108	N	3,5				
	133	N	4				
	159	N	4,5				
PSV/5-FHD	89	N	3	30	22	6306	
	108	N	3,5				
	133	N	4				
	159	N	4,5				
PSV/7-FHD	108	N	4	40	32	6308	
	133	N	4				
	159	N	4,5				
	194	N	6,3				
	219	N	6,3				



2 Rollers

series PSV/1-FHD

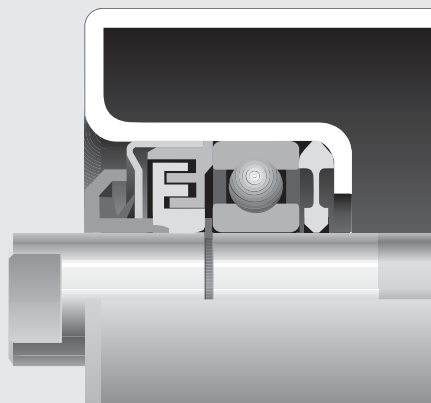

Section through sealing

Ø 63 N

Bearing 6204
(20 X 47 X 14)

d = 20
ch = 14
s = 3
e = 4
g = 9

belt width mm	roller dimensions mm			weight Kg		load capacity daN					
	arrangements 			rotating parts total		belt speed m/s					
	B	C	A			0.5	1	1.25	1.5	1.75	2
400	160	168	186	1.3	1.8	201	160	148	140	133	127
300 500	200	208	226	1.5	2.1	201	160	148	140	133	127
400 650	250	258	276	1.7	2.4	201	160	148	140	133	127
500 800	315	323	341	2.0	2.9	201	160	148	140	133	127
300 650 1000	380	388	406	2.3	3.3	201	160	148	140	133	127
800 1200	465	473	491	2.7	3.9	201	160	148	140	133	127
400	500	508	526	2.9	4.1	201	160	148	140	133	127
500 1000	600	608	626	3.3	4.8	201	160	148	140	133	127
1200	700	708	726	3.8	5.5	184	160	148	140	133	127
650	750	758	776	4.0	5.9	172	160	148	140	133	127
800	950	958	976	4.9	7.3	138	138	138	138	133	127
1000	1150	1158	1176	5.8	8.7	116	116	116	116	116	116
1200	1400	1408	1426	6.9	10.4	99	99	99	99	99	99

The indicated load capacity relates to a project working life of 30,000 hours.

Example of ordering
standard design
PSV/1-FHD,20F,63N,608

for special design
see pages 80-81

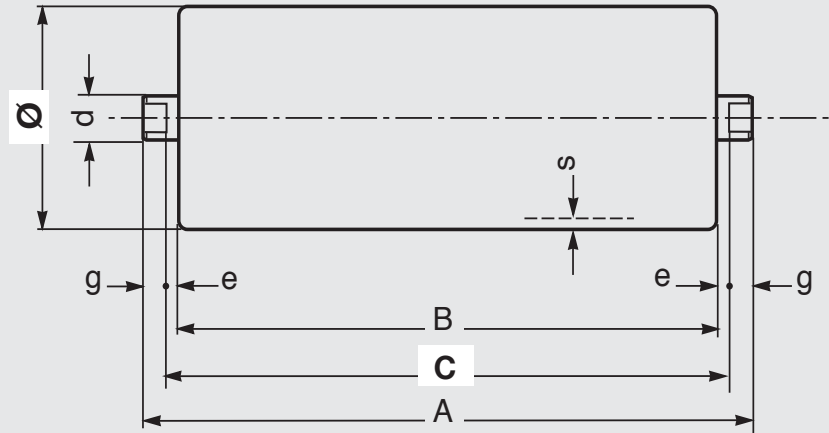
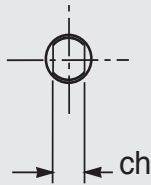

Ø 89 N

Bearing 6204
(20 X 47 X 14)

- d = 20
- ch = 14
- s = 3
- e = 4
- g = 9

belt		roller										
width mm		dimensions mm			weight Kg		load capacity daN					
arrangements		B	C	A	rotating parts		belt speed m/s					
					parts	total	0.5	1	1.5	2	2.5	3
400		160	168	186	1.7	2.2	226	179	157	142	132	124
300	500	200	208	226	2.0	2.5	226	179	157	142	132	124
400	650	250	258	276	2.3	3.0	226	179	157	142	132	124
500	800	315	323	341	2.7	3.6	226	179	157	142	132	124
300	650 1000	380	388	406	3.1	4.1	226	179	157	142	132	124
	800 1200	465	473	491	3.7	4.9	226	179	157	142	132	124
400		500	508	526	3.9	5.2	226	179	157	142	132	124
	1400	530	538	556	4.1	5.5	226	179	157	142	132	124
500	1000	600	608	626	4.6	6.1	204	179	157	142	132	124
	1200	700	708	726	5.2	7.0	173	173	157	142	132	124
650		750	758	776	5.5	7.4	161	161	157	142	132	124
	1400	800	808	826	5.8	7.9	150	150	150	142	132	124
800		950	958	976	6.8	9.2	126	126	126	126	126	124
1000		1150	1158	1176	8.1	11.0	104	104	104	104	104	104
1200		1400	1408	1426	9.7	13.2	85	85	85	85	85	85
1400		1600	1608	1626	11.0	15.0	75	75	75	75	75	75

The indicated load capacity relates to a project working life of 30,000 hours.

Example of ordering
standard design
PSV/1-FHD,20F,89N,608

for special design
see pages 80-81



2 Rollers

series PSV/1-FHD

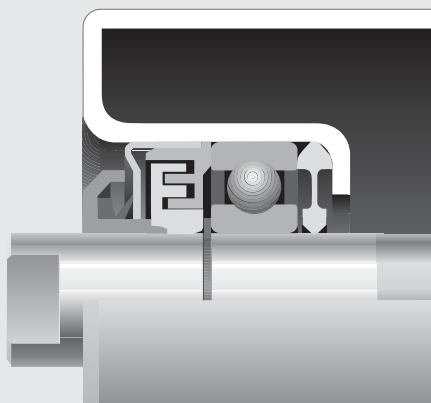

Section through sealing

Ø 108 N

Bearing 6204
(20 X 47 X 14)

d = 20
ch = 14
s = 3,5
e = 4
g = 9

belt		roller						load capacity					
width mm		dimensions mm			weight Kg		daN						
arrangements		B	C	A	rotating parts		belt speed m/s						
					total	1	1.5	2	2.5	3	3.5		
400		160	168	186	2.3	2.7	191	167	152	141	133	126	
300	500	200	208	226	2.6	3.2	191	167	152	141	133	126	
400	650	250	258	276	3.1	3.8	191	167	152	141	133	126	
500	800	315	323	341	3.7	4.5	191	167	152	141	133	126	
300	650 1000	380	388	406	4.3	5.3	191	167	152	141	133	126	
800	1200	465	473	491	5.0	6.2	191	167	152	141	133	126	
400		500	508	526	5.3	6.6	191	167	152	141	133	126	
	1400	530	538	556	5.6	7.0	191	167	152	141	133	126	
500	1000	600	608	626	6.2	7.8	191	167	152	141	133	126	
	1200	700	708	726	7.1	8.9	170	167	152	141	133	126	
650		750	758	776	7.6	9.5	158	158	152	141	133	126	
	1400	800	808	826	8.1	10.1	147	147	147	141	133	126	
800		950	958	976	9.4	11.8	123	123	123	123	123	123	
1000		1150	1158	1176	11.2	14.1	101	101	101	101	101	101	
1200		1400	1408	1426	13.5	17.0	82	82	82	82	82	82	
1400		1600	1608	1626	15.3	19.3	72	72	72	72	72	72	

The indicated load capacity relates to a project working life of 30,000 hours.

Example of ordering
standard design
PSV/1-FHD,20F,108N,323

for special design
see pages 80-81

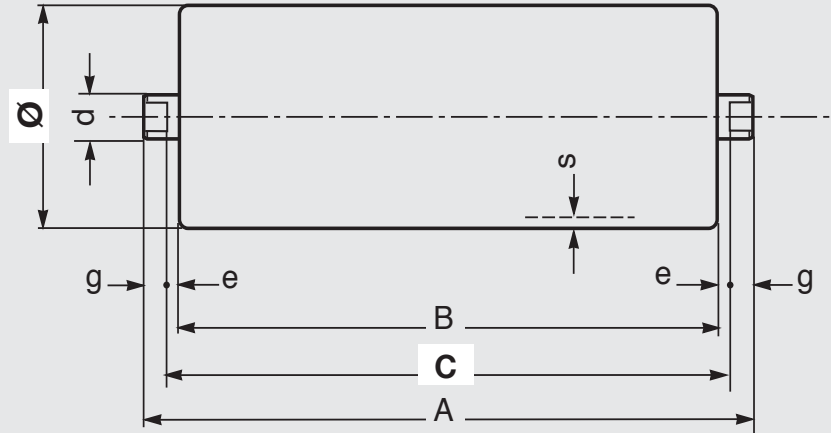
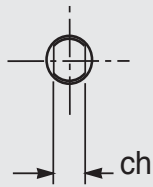

Ø 133 N

Bearing 6204
(20 X 47 X 14)

d = 20
ch = 14
s = 4
e = 4
g = 9

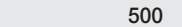
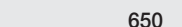
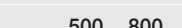
width mm	roller			weight Kg		load capacity daN					
	dimensions mm			rotating parts	total	belt speed m/s					
arrangements	B	C	A			1	1.5	2	2.5	3	4
 500	200	208	226	3.6	4.1	205	179	163	151	142	129
650	250	258	276	4.2	4.9	205	179	163	151	142	129
 500 800	315	323	341	5.0	5.9	205	179	163	151	142	129
650 1000	380	388	406	5.9	6.9	205	179	163	151	142	129
 800 1200	465	473	491	6.9	8.1	205	179	163	151	142	129
1400	530	538	556	7.8	9.1	205	179	163	151	142	129
 500 1000 1600	600	608	626	8.7	10.2	200	179	163	151	142	129
1200	700	708	726	9.9	11.7	169	169	163	151	142	129
650	750	758	776	10.6	12.5	157	157	157	151	142	129
1400	800	808	826	11.2	13.2	146	146	146	146	142	129
1600	900	908	926	12.5	14.8	129	129	129	129	129	129
800	950	958	976	13.1	15.5	122	122	122	122	122	122
1000	1150	1158	1176	15.7	18.6	99	99	99	99	99	99
1200	1400	1408	1426	18.9	22.4	81	81	81	81	81	81
1400	1600	1608	1626	21.4	25.4	71	71	71	71	71	71
1600	1800	1808	1826	24.0	28.4	63	63	63	63	63	63

The indicated load capacity relates to a project working life of 30,000 hours.

Example of ordering
standard design
PSV/1-FHD,20F,133N,388

for special design
see pages 80-81



2 Rollers

series PSV/2-FHD

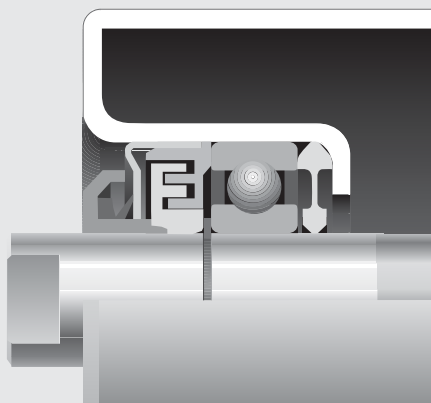

Section through sealing

Ø 89 N

Bearing 6205
(25 X 52 X 15)

d = 25
ch = 18
s = 3
e = 4
g = 12

belt width mm	roller dimensions mm			weight Kg		load capacity daN					
	B	C	A	rotating parts	total	belt speed m/s					
arrangements 						0.5	1	1.5	2	2.5	3
500	200	208	232	2.1	3.0	346	274	240	218	202	190
650	250	258	282	2.4	3.5	346	274	240	218	202	190
500 800	315	323	347	2.9	4.2	346	274	240	218	202	190
650 1000	380	388	412	3.3	4.9	346	274	240	218	202	190
800 1200	465	473	497	3.8	5.7	346	274	240	218	202	190
1400	530	538	562	4.2	6.4	346	274	240	218	202	190
500 1000 1600	600	608	632	4.7	7.1	346	274	240	218	202	190
1200	700	708	732	5.3	8.1	346	274	240	218	202	190
650	750	758	782	5.7	8.6	346	274	240	218	202	190
1400	800	808	832	6.0	9.2	346	274	240	218	202	190
1600	900	908	932	6.6	10.2	336	274	240	218	202	190
800	950	958	982	6.9	10.7	319	274	240	218	202	190
1000	1150	1158	1182	8.2	12.7	267	267	240	218	202	190
1200	1400	1408	1432	9.8	15.3	224	224	224	218	202	190
1400	1600	1608	1632	11.1	17.4	201	201	201	201	201	
1600	1800	1808	1832	12.4	19.4	183	183	183	183	183	

The indicated load capacity relates to a project working life of 30,000 hours.

Example of ordering
standard design
PSV/2-FHD,25F,89N,323

for special design
see pages 80-81

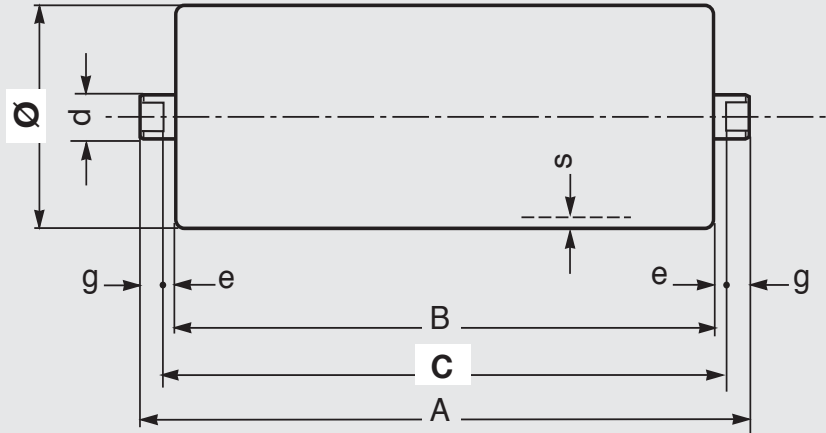
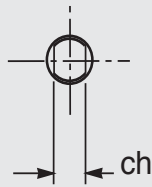

Ø 108 N

Bearing 6205
(25 X 52 X 15)

d = 25
ch = 18
s = 3,5
e = 4
g = 12

width mm	roller			weight Kg		load capacity daN					
	dimensions mm			rotating parts	total	belt speed m/s					
arrangements	B	C	A			1	1.5	2	2.5	3	3.5
500	200	208	232	2.7	3.6	293	256	232	216	203	193
650	250	258	282	3.2	4.3	293	256	232	216	203	193
500 800	315	323	347	3.8	5.1	293	256	232	216	203	193
650 1000	380	388	412	4.4	6.0	293	256	232	216	203	193
800 1200	465	473	497	5.1	7.0	293	256	232	216	203	193
1400	530	538	562	5.7	7.9	293	256	232	216	203	193
500 1000 1600	600	608	632	6.4	8.8	293	256	232	216	203	193
1200	700	708	732	7.3	10.1	293	256	232	216	203	193
650	750	758	782	7.7	10.7	293	256	232	216	203	193
1400	800	808	832	8.2	11.4	293	256	232	216	203	193
1600	900	908	932	9.1	12.6	293	256	232	216	203	193
800	950	958	982	9.5	13.3	293	256	232	216	203	193
1000	1150	1158	1182	11.3	15.9	249	249	232	216	203	193
1200	1400	1408	1432	13.6	19.1	205	205	205	205	203	193
1400	1600	1608	1632	15.4	21.7	180	180	180	180	180	180
1600	1800	1808	1832	17.2	24.2	161	161	161	161	161	

The indicated load capacity relates to a project working life of 30,000 hours.

Example of ordering
standard design
PSV/2-FHD,25F,108N,958

for special design
see pages 80-81



2 Rollers

series PSV/2-FHD

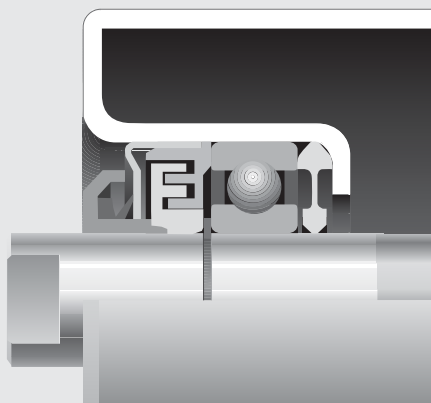

Section through sealing

Ø 133 N

Bearing 6205
(25 X 52 X 15)

d = 25
ch = 18
s = 4
e = 4
g = 12

Example of ordering
standard design
PSV/2-FHD,25F,133N,473

for special design
see pages 80-81

belt		roller										
width mm		dimensions mm			weight Kg		load capacity daN					
arrangements 	B	C	A	rotating parts		belt speed m/s						
				parts	total	1	1.5	2	2.5	3	4	
650	250	258	282	4.5	5.5	314	274	249	231	217	198	
800	315	323	347	5.3	6.5	314	274	249	231	217	198	
650 1000	380	388	412	6.1	7.6	314	274	249	231	217	198	
800 1200	465	473	497	7.2	9.0	314	274	249	231	217	198	
1400	530	538	562	8.0	10.1	314	274	249	231	217	198	
1000 1600	600	608	632	8.9	11.3	314	274	249	231	217	198	
1800	670	678	702	9.8	12.4	314	274	249	231	217	198	
1200	700	708	732	10.2	12.9	314	274	249	231	217	198	
650	750	758	782	10.9	13.8	314	274	249	231	217	198	
1400	800	808	832	11.5	14.6	314	274	249	231	217	198	
1600	900	908	932	12.8	16.2	310	274	249	231	217	198	
800	950	958	982	13.4	17.1	293	274	249	231	217	198	
1800	1000	1008	1032	14.0	17.9	278	274	249	231	217	198	
1000	1150	1158	1182	16.0	20.4	240	240	240	231	217	198	
1200	1400	1408	1432	19.1	24.5	197	197	197	197	197	197	
1400	1600	1608	1632	21.7	27.9	172	172	172	172	172	172	
1600	1800	1808	1832	24.2	31.2	153	153	153	153	153	153	
1800	2000	2008	2032	26.8	34.5	138	138	138	138	138	138	

The indicated load capacity relates to a project working life of 30,000 hours.

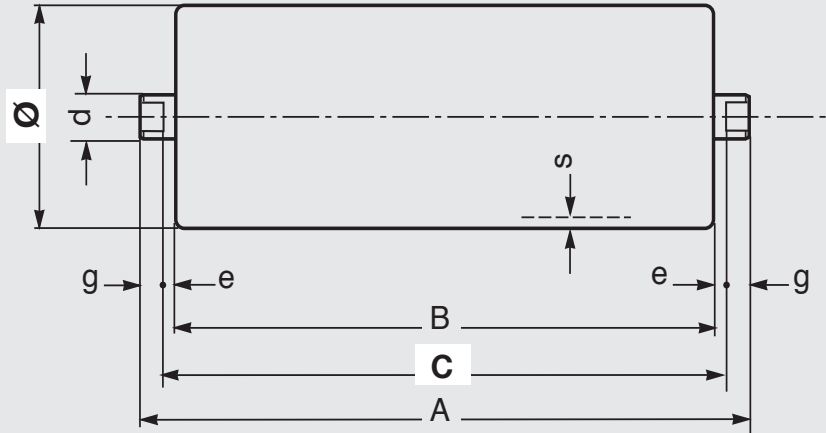
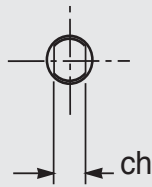

Ø 159 N

Bearing 6205
(25 X 52 X 15)

- d = 25
- ch = 18
- s = 4,5
- e = 4
- g = 12

Example of ordering
standard design
PSV/2-FHD,25F,159N,1158

for special design
see pages 80-81

belt	roller			weight		load capacity					
	width mm	dimensions mm			Kg		daN				
arrangements 	B	C	A	rotating parts		belt speed m/s					
				parts	total	1	2	3	4	4.5	5
650	250	258	282	5.3	6.3	333	264	231	210	202	195
800	315	323	347	6.3	7.6	333	264	231	210	202	195
650 1000	380	388	412	7.3	8.8	333	264	231	210	202	195
800 1200	465	473	497	8.6	10.5	333	264	231	210	202	195
1400	530	538	562	9.6	11.7	333	264	231	210	202	195
1000 1600	600	608	632	10.6	13.1	333	264	231	210	202	195
1800	670	678	702	11.7	14.4	333	264	231	210	202	195
1200	700	708	732	12.2	15.0	333	264	231	210	202	195
650	750	758	782	12.9	15.9	333	264	231	210	202	195
1400	800	808	832	13.7	16.9	333	264	231	210	202	195
1600	900	908	932	15.2	18.8	307	264	231	210	202	195
800	950	958	982	16.0	19.8	290	264	231	210	202	195
1800	1000	1008	1032	16.8	20.7	275	264	231	210	202	195
1000	1150	1158	1182	19.1	23.6	237	237	231	210	202	195
1200	1400	1408	1432	22.9	28.4	193	193	193	193	193	193
1400	1600	1608	1632	26.0	32.2	169	169	169	169	169	169
1600	1800	1808	1832	29.0	36.0	150	150	150	150	150	150
1800	2000	2008	2032	32.1	39.9	134	134	134	134	134	134

The indicated load capacity relates to a project working life of 30,000 hours.



2 Rollers

series PSV/3-FHD

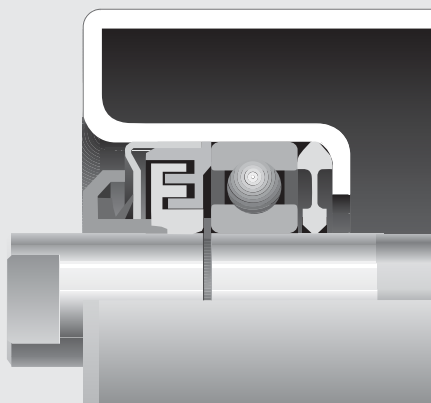

Section through sealing

Ø 89 N

Bearing 6305
(25 X 62 X 17)

d = 25
ch = 18
s = 3
e = 4
g = 12

belt	roller			weight		load capacity					
	width mm	dimensions mm			Kg		daN				
arrangements 	B	C	A	rotating		belt speed m/s					
				parts	total	0.5	1	1.5	2	2.5	3
650	250	258	282	2.8	3.9	509	404	353	321	298	280
800	315	323	347	3.2	4.5	509	404	353	321	298	280
650 1000	380	388	412	3.6	5.2	509	404	353	321	298	280
800 1200	465	473	497	4.2	6.1	509	404	353	321	298	280
1400	530	538	562	4.6	6.7	509	404	353	321	298	280
1000 1600	600	608	632	5.0	7.5	493	404	353	321	298	280
1200	700	708	732	5.7	8.5	420	404	353	321	298	280
650	750	758	782	6.0	9.0	392	392	353	321	298	280
1400	800	808	832	6.3	9.5	367	367	353	321	298	280
1600	900	908	932	7.0	10.5	327	327	327	321	298	280
800	950	958	982	7.3	11.1	310	310	310	310	298	280
1000	1150	1158	1182	8.6	13.1	259	259	259	259	259	259
1200	1400	1408	1432	10.2	15.7	218	218	218	218	218	218
1400	1600	1608	1632	11.5	17.7	194	194	194	194	194	194
1600	1800	1808	1832	12.8	19.8	177	177	177	177	177	177

The indicated load capacity relates to a project working life of 30,000 hours.

Example of ordering
standard design
PSV/3-FHD,25F,89N,323

for special design
see pages 80-81

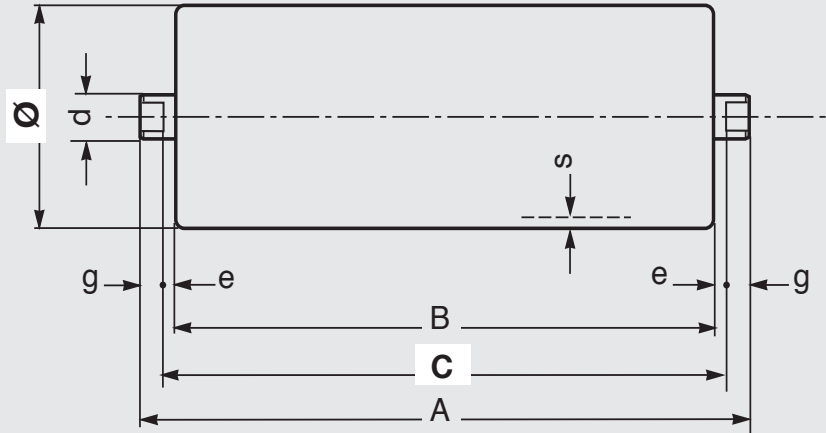
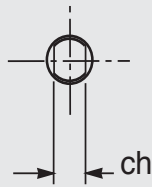

Ø 108 N

Bearing 6305
(25 X 62 X 17)

- d = 25
- ch = 18
- s = 3,5
- e = 4
- g = 12

belt		roller										
width mm		dimensions mm			weight Kg		load capacity daN					
arrangements 		B	C	A	rotating parts		belt speed m/s					
					parts	total	1	1.5	2	2.5	3	3.5
	650	250	258	282	3.6	4.7	431	376	342	317	299	284
	800	315	323	347	4.2	5.5	431	376	342	317	299	284
	650 1000	380	388	412	4.8	6.4	431	376	342	317	299	284
	800 1200	465	473	497	5.5	7.5	431	376	342	317	299	284
	1400	530	538	562	6.1	8.3	431	376	342	317	299	284
	1000 1600	600	608	632	6.8	9.2	431	376	342	317	299	284
	1200	700	708	732	7.7	10.5	404	376	342	317	299	284
	650	750	758	782	8.1	11.1	375	375	342	317	299	284
	1400	800	808	832	8.6	11.8	351	351	342	317	299	284
	1600	900	908	932	9.5	13.0	310	310	310	310	299	284
	800	950	958	982	9.9	13.7	294	294	294	294	294	284
	1000	1150	1158	1182	11.7	16.3	242	242	242	242	242	242
	1200	1400	1408	1432	14.0	19.5	199	199	199	199	199	199
	1400	1600	1608	1632	15.8	22.1	175	175	175	175	175	175
	1600	1800	1808	1832	17.6	24.6	157	157	157	157	157	157

The indicated load capacity relates to a project working life of 30,000 hours.

Example of ordering
standard design
PSV/3-FHD,25F,108N,958

for special design
see pages 80-81



2 Rollers

series PSV/3-FHD

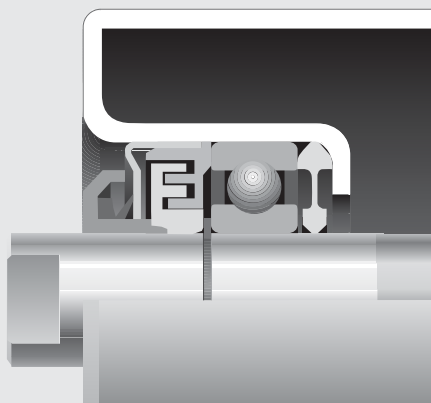

Section through sealing

Ø 133 N

Bearing 6305
(25 X 62 X 17)

d = 25
ch = 18
s = 4
e = 4
g = 12

Example of ordering
standard design
PSV/3-FHD,25F,133N,473

for special design
see pages 80-81

belt	roller						load capacity					
	dimensions mm			weight Kg		daN						
width mm	arrangements			rotating parts		belt speed m/s						
	B	C	A	parts	total	1	1.5	2	2.5	3	4	
800	315	323	347	5.7	7.0	462	403	366	340	320	291	
1000	380	388	412	6.5	8.1	462	403	366	340	320	291	
800 1200	465	473	497	7.6	9.5	462	403	366	340	320	291	
1400	530	538	562	8.4	10.6	462	403	366	340	320	291	
1000 1600	600	608	632	9.3	11.7	462	403	366	340	320	291	
1800	670	678	702	10.2	12.9	416	403	366	340	320	291	
1200	700	708	732	10.6	13.4	397	397	366	340	320	291	
2000	750	758	782	11.2	14.2	368	368	366	340	320	291	
1400	800	808	832	11.9	15.1	343	343	343	340	320	291	
1600	900	908	932	13.1	16.7	303	303	303	303	303	291	
800	950	958	982	13.8	17.5	286	286	286	286	286	286	
1800	1000	1008	1032	14.4	18.4	271	271	271	271	271	271	
2000	1100	1108	1132	15.7	20.0	245	245	245	245	245	245	
1000	1150	1158	1182	16.3	20.9	234	234	234	234	234	234	
1200	1400	1408	1432	19.5	25.0	192	192	192	192	192	192	
1400	1600	1608	1632	22.1	28.3	167	167	167	167	167	167	
1600	1800	1808	1832	24.6	31.6	149	149	149	149	149	149	
1800	2000	2008	2032	27.2	35.0	134	134	134	134	134	134	

The indicated load capacity relates to a project working life of 30,000 hours.

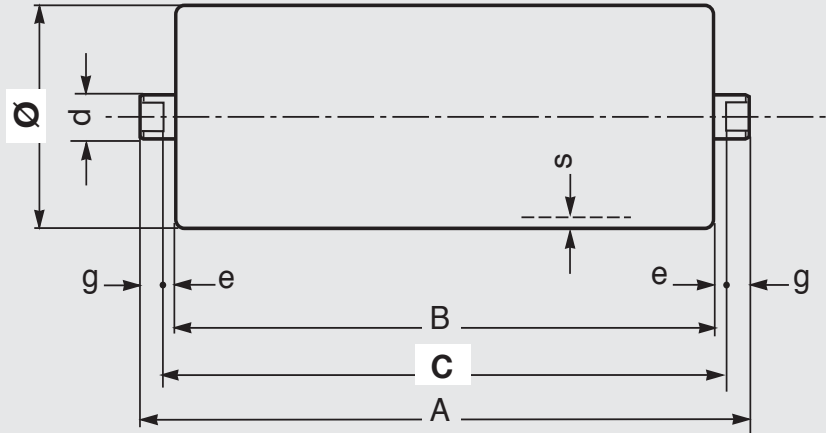
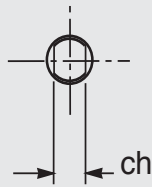

Ø 159 N

Bearing 6305
(25 X 62 X 17)

- d = 25
- ch = 18
- s = 4,5
- e = 4
- g = 12

belt	roller			weight		load capacity					
	width mm	dimensions mm			Kg	daN					
arrangements 	B	C	A	rotating parts	total	belt speed m/s					
						1	2	3	4	4.5	5
1000	380	388	412	7.8	9.4	490	389	340	309	297	287
1200	465	473	497	9.1	11.0	490	389	340	309	297	287
1400	530	538	562	10.1	12.3	490	389	340	309	297	287
1000 1600	600	608	632	11.2	13.6	467	389	340	309	297	287
1800	670	678	702	12.3	15.0	413	389	340	309	297	287
1200	700	708	732	12.7	15.5	393	389	340	309	297	287
2000	750	758	782	13.5	16.5	365	365	340	309	297	287
1400	800	808	832	14.3	17.4	340	340	340	309	297	287
1600	900	908	932	15.8	19.4	300	300	300	300	297	287
1800	1000	1008	1032	17.3	21.3	268	268	268	268	268	268
2000	1100	1108	1132	18.9	23.2	242	242	242	242	242	242
1000	1150	1158	1182	19.6	24.1	231	231	231	231	231	231
1200	1400	1408	1432	23.5	28.9	188	188	188	188	188	188
1400	1600	1608	1632	26.5	32.8	164	164	164	164	164	164
1600	1800	1808	1832	29.6	36.6	146	146	146	146	146	146
1800	2000	2008	2032	32.6	40.4	131	131	131	131	131	131
2000	2200	2208	2232	35.7	44.3	119	119	119	119	119	119

Example of ordering
standard design
PSV/3-FHD,25F,159N,1158

for special design
see pages 80-81

The indicated load capacity relates to a project working life of 30,000 hours.



2 Rollers

series PSV/4-FHD

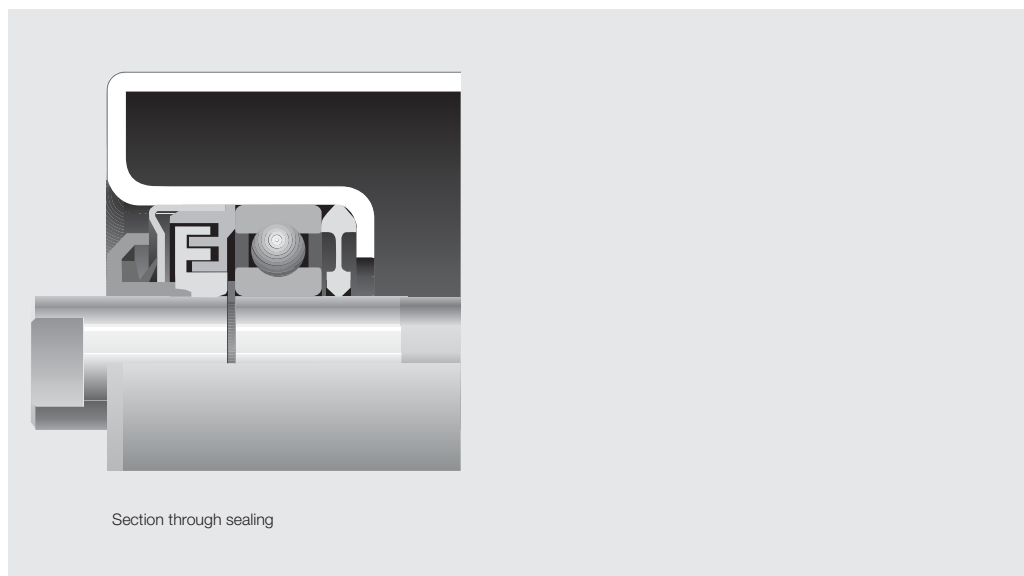

Section through sealing

Ø 89 N

Bearing 6206
(30 X 62 X 16)

d = 30
ch = 22
s = 3
e = 4
g = 12

belt		roller										
width mm		dimensions mm			weight Kg		load capacity daN					
arrangements 		B	C	A	rotating parts total		belt speed m/s					
							0.5	1	1.5	2	2.5	3
	800	315	323	347	3.4	5.3	480	381	333	302	281	264
	1000	380	388	412	3.8	6.1	480	381	333	302	281	264
	800 1200	465	473	497	4.3	7.1	480	381	333	302	281	264
	1400	530	538	562	4.8	7.9	480	381	333	302	281	264
	1000 1600	600	608	632	5.2	8.7	480	381	333	302	281	264
	1200	700	708	732	5.9	9.9	480	381	333	302	281	264
	1400	800	808	832	6.5	11.1	480	381	333	302	281	264
	1600	900	908	932	7.1	12.3	480	381	333	302	281	264
	800	950	958	982	7.5	12.9	480	381	333	302	281	264
	1000	1150	1158	1182	8.7	15.3	480	381	333	302	281	264
	1200	1400	1408	1432	10.4	18.3	480	381	333	302	281	264
	1400	1600	1608	1632	11.6	20.6	337	337	333	302	281	264
	1600	1800	1808	1832	12.9	23.0	233	233	233	233	233	233

The indicated load capacity relates to a project working life of 30,000 hours.

Example of ordering
standard design
PSV/4-FHD,30F,89N,323

for special design
see pages 80-81

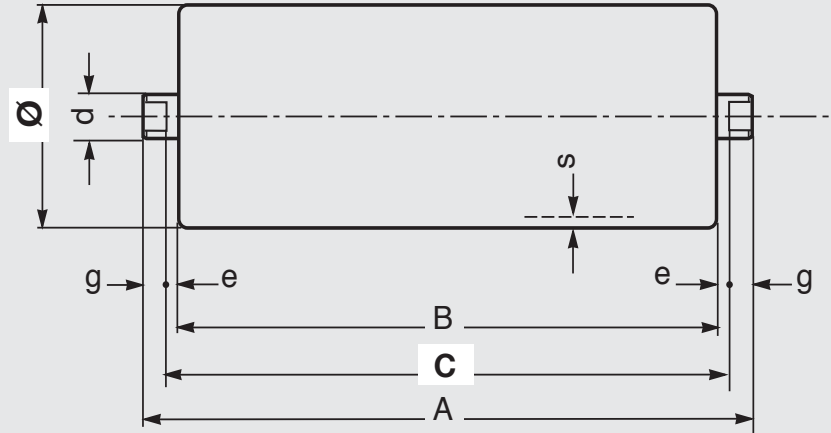
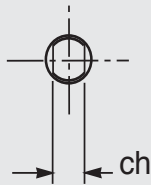

Ø 108 N

Bearing 6206
(30 X 62 X 16)

d = 30
ch = 22
s = 3,5
e = 4
g = 12

belt	roller												
	width mm	dimensions mm			weight Kg		load capacity daN						
arrangements						rotating parts total		belt speed m/s					
	B	C	A			1	1.5	2	2.5	3	3.5		
800	315	323	347	4.3	6.3	406	355	323	299	282	268		
1000	380	388	412	4.9	7.2	406	355	323	299	282	268		
800 1200	465	473	497	5.7	8.4	406	355	323	299	282	268		
1400	530	538	562	6.3	9.4	406	355	323	299	282	268		
1000 1600	600	608	632	6.9	10.4	406	355	323	299	282	268		
1200	700	708	732	7.8	11.9	406	355	323	299	282	268		
1400	800	808	832	8.7	13.3	406	355	323	299	282	268		
1600	900	908	932	9.6	14.8	406	355	323	299	282	268		
800	950	958	982	10.1	15.5	406	355	323	299	282	268		
1000	1150	1158	1182	11.9	18.4	406	355	323	299	282	268		
1200	1400	1408	1432	14.2	22.1	406	355	323	299	282	268		
1400	1600	1608	1632	16.0	25.0	402	355	323	299	282	268		
1600	1800	1808	1832	17.8	27.9	366	355	323	299	282	268		

The indicated load capacity relates to a project working life of 30,000 hours.

Example of ordering
standard design
PSV/4-FHD,30F,108N,958

for special design
see pages 80-81



2 Rollers

series PSV/4-FHD

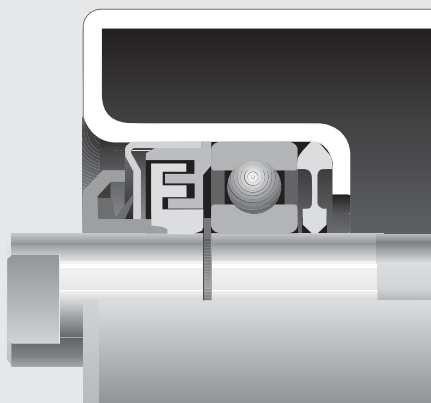

Section through sealing

Ø 133 N

Bearing 6206
(30 X 62 X 16)

d = 30
ch = 22
s = 4
e = 4
g = 12

Example of ordering
standard design
PSV/4-FHD,30F,133N,473

for special design
see pages 80-81

belt		roller										
width mm		dimensions mm			weight Kg		load capacity daN					
arrangements 	B	C	A	rotating parts		belt speed m/s						
				total	1	1.5	2	2.5	3	4		
800	315	323	347	5.8	7.8	436	381	346	321	302	274	
1000	380	388	412	6.7	8.9	436	381	346	321	302	274	
800 1200	465	473	497	7.8	10.5	436	381	346	321	302	274	
1400	530	538	562	8.6	11.7	436	381	346	321	302	274	
1000 1600	600	608	632	9.5	13.0	436	381	346	321	302	274	
1800	670	678	702	10.4	14.2	436	381	346	321	302	274	
1200	700	708	732	10.8	14.8	436	381	346	321	302	274	
2000	750	758	782	11.4	15.7	436	381	346	321	302	274	
1400	800	808	832	12.0	16.6	436	381	346	321	302	274	
1600	900	908	932	13.3	18.5	436	381	346	321	302	274	
800	950	958	982	14.0	19.4	436	381	346	321	302	274	
1800	1000	1008	1032	14.6	20.3	436	381	346	321	302	274	
2000	1100	1108	1132	15.9	22.1	436	381	346	321	302	274	
1000	1150	1158	1182	16.5	23.0	436	381	346	321	302	274	
1200	1400	1408	1432	19.7	27.6	412	381	346	321	302	274	
1400	1600	1608	1632	22.3	31.3	363	363	346	321	302	274	
1600	1800	1808	1832	24.8	34.9	324	324	324	321	302	274	
1800	2000	2008	2032	27.4	38.6	294	294	294	294	294	274	
2000	2200	2208	2232	29.9	42.2	270	270	270	270	270	270	

The indicated load capacity relates to a project working life of 30,000 hours.

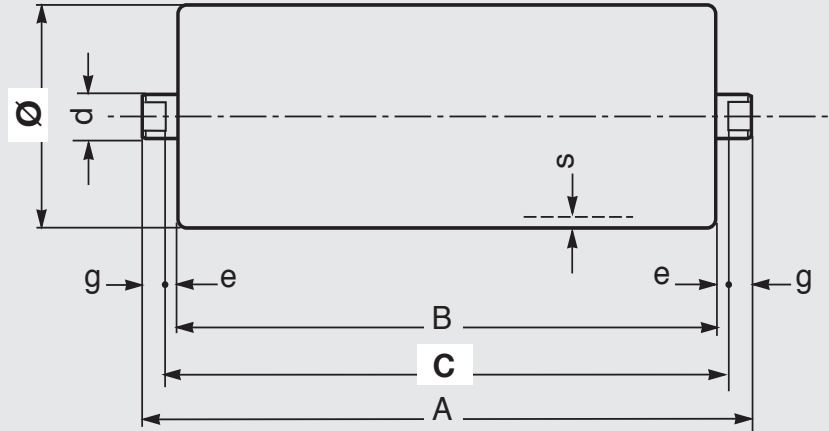
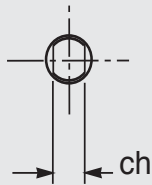

Ø 159 N

Bearing 6206
(30 X 62 X 16)

d = 30
ch = 22
s = 4,5
e = 4
g = 12

Example of ordering
standard design
PSV/4-FHD,30F,159N,473

for special design
see pages 80-81

belt	roller			weight Kg		load capacity daN						
	width mm	dimensions mm				belt speed m/s						
arrangements	B	C	A	rotating parts	total	1	2	3	4	4.5	5	
	800	315	323	347	7.0	8.9	462	367	321	291	280	270
	1000	380	388	412	8.0	10.3	462	367	321	291	280	270
	800 1200	465	473	497	9.3	12.1	462	367	321	291	280	270
	1400	530	538	562	10.3	13.4	462	367	321	291	280	270
	1000 1600	600	608	632	11.4	14.9	462	367	321	291	280	270
	1800	670	678	702	12.5	16.3	462	367	321	291	280	270
	1200	700	708	732	12.9	17.0	462	367	321	291	280	270
	2000	750	758	782	13.7	18.0	462	367	321	291	280	270
	1400	800	808	832	14.5	19.1	462	367	321	291	280	270
	1600	900	908	932	16.0	21.1	462	367	321	291	280	270
	800	950	958	982	16.8	22.2	462	367	321	291	280	270
	1800	1000	1008	1032	17.5	23.2	462	367	321	291	280	270
	2000	1100	1108	1132	19.1	25.3	462	367	321	291	280	270
	1000	1150	1158	1182	19.8	26.4	462	367	321	291	280	270
	1200	1400	1408	1432	23.7	31.6	398	367	321	291	280	270
	1400	1600	1608	1632	26.7	35.7	348	348	321	291	280	270
	1600	1800	1808	1832	29.8	39.9	310	310	310	291	280	270
	1800	2000	2008	2032	32.9	44.1	279	279	279	279	279	279
	2000	2200	2208	2232	35.9	48.2	254	254	254	254	254	254

The indicated load capacity relates to a project working life of 30,000 hours.



2 Rollers

series PSV/5-FHD

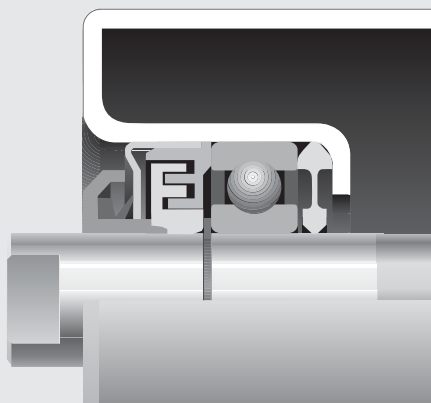

Section through sealing

Ø 89 N

Bearing 6306
(30 X 72 X 19)

d = 30
ch = 22
s = 3 *
e = 4
g = 12

*s = 4 for basic rollers with
impact rings

Example of ordering
standard design
PSV/5-FHD,30F,89N,323

for special design
see pages 80-81

belt	roller						load capacity					
	width mm	dimensions mm			weight Kg		daN					
arrangements 	B	C	A	rotating parts		belt speed m/s						
				total	1	1.5	2	2.5	3	3.5		
800	315	323	347	3.9	5.8	549	479	435	404	380	361	
1000	380	388	412	4.3	6.6	549	479	435	404	380	361	
800 1200	465	473	497	4.9	7.6	549	479	435	404	380	361	
1400	530	538	562	5.3	8.4	549	479	435	404	380	361	
1000 1600	600	608	632	5.8	9.2	549	479	435	404	380	361	
1800	670	678	702	6.2	10.1	549	479	435	404	380	361	
1200	700	708	732	6.4	10.4	549	479	435	404	380	361	
2000	750	758	782	6.7	11.0	549	479	435	404	380	361	
1400	800	808	832	7.0	11.6	549	479	435	404	380	361	
1600	900	908	932	7.7	12.8	549	479	435	404	380	361	
800	950	958	982	8.0	13.4	549	479	435	404	380	361	
1800	1000	1008	1032	8.3	14.0	549	479	435	404	380	361	
2000	1100	1108	1132	9.0	15.2	549	479	435	404	380	361	
1000	1150	1158	1182	9.3	15.8	549	479	435	404	380	361	
1200	1400	1408	1432	10.9	18.8	512	479	435	404	380	361	
1400	1600	1608	1632	12.2	21.2	337	337	337	337	337	337	
1600	1800	1808	1832	13.5	23.6	233	233	233	233	233	233	
1800	2000	2008	2032	14.8	26.0	168	168	168	168			
2000	2200	2208	2232	16.1	28.4	125	125	125				

The indicated load capacity relates to a project working life of 30,000 hours.

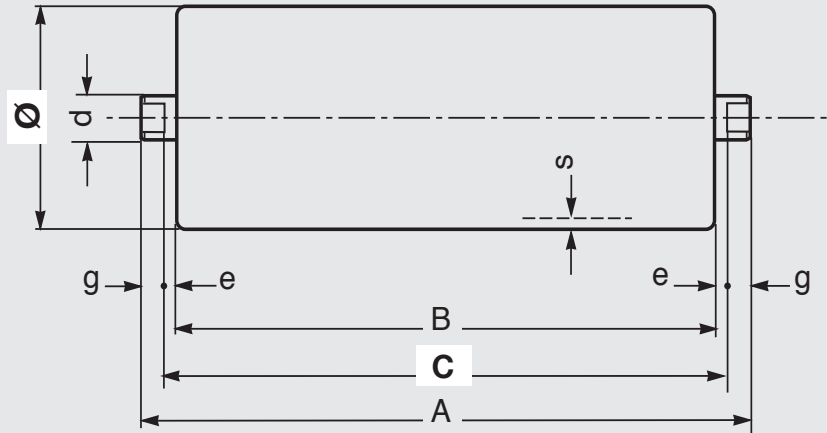
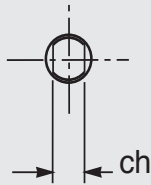

Ø 108 N

Bearing 6306
(30 X 72 X 19)

d = 30
ch = 22
s = 3,5
e = 4
g = 12

belt	roller			weight		load capacity					
	width mm	dimensions mm			Kg		daN				
arrangements 	B	C	A	rotating		belt speed m/s					
				parts	total	1	2	2.5	3	3.5	4
800	315	323	347	4.9	6.8	585	465	431	406	385	369
1000	380	388	412	5.5	7.8	585	465	431	406	385	369
800 1200	465	473	497	6.3	9.0	585	465	431	406	385	369
1400	530	538	562	6.9	10.0	585	465	431	406	385	369
1000 1600	600	608	632	7.5	11.0	585	465	431	406	385	369
1800	670	678	702	8.1	12.0	585	465	431	406	385	369
1200	700	708	732	8.4	12.5	585	465	431	406	385	369
2000	750	758	782	8.9	13.2	585	465	431	406	385	369
1400	800	808	832	9.3	13.9	585	465	431	406	385	369
1600	900	908	932	10.2	15.4	585	465	431	406	385	369
800	950	958	982	10.7	16.1	585	465	431	406	385	369
1800	1000	1008	1032	11.1	16.8	585	465	431	406	385	369
2000	1100	1108	1132	12.0	18.3	560	465	431	406	385	369
1000	1150	1158	1182	12.5	19.0	537	465	431	406	385	369
1200	1400	1408	1432	14.8	22.7	451	451	431	406	385	369
1400	1600	1608	1632	16.6	25.6	402	402	402	402	385	369
1600	1800	1808	1832	18.4	28.5	366	366	366	366	366	
1800	2000	2008	2032	20.2	31.4	337	337	337	337		
2000	2200	2208	2232	22.0	34.3	261	261	261			

Example of ordering
standard design
PSV/5-FHD,30F,108N,473

for special design
see pages 80-81

The indicated load capacity relates to a project working life of 30,000 hours.



2 Rollers

series PSV/5-FHD

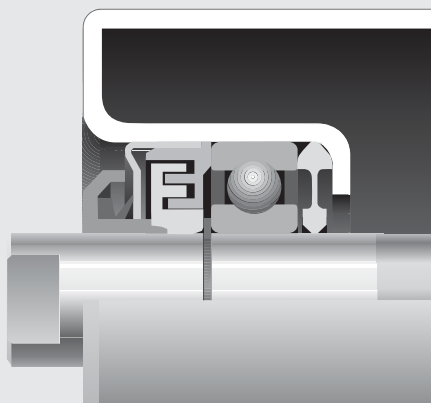

Section through sealing

Ø 133 N

Bearing 6306
(30 X 72 X 19)

d = 30
ch = 22
s = 4
e = 4
g = 12

Example of ordering
standard design
PSV/5-FHD,30F,133N,473

for special design
see pages 80-81

belt		roller					weight		load capacity					
width	mm	dimensions			mm	Kg	daN							
arrangements	B	C	A	rotating		belt speed m/s								
				parts	total	1	2	3	4	4.5	5			
	800	315	323	347	6.4	8.3	627	498	435	395	380	367		
	1000	380	388	412	7.2	9.5	627	498	435	395	380	367		
	800 1200	465	473	497	8.3	11.1	627	498	435	395	380	367		
	1400	530	538	562	9.2	12.3	627	498	435	395	380	367		
	1000 1600	600	608	632	10.1	13.5	627	498	435	395	380	367		
	1800	670	678	702	10.9	14.8	627	498	435	395	380	367		
	1200	700	708	732	11.3	15.4	627	498	435	395	380	367		
	2000	750	758	782	12.0	16.3	627	498	435	395	380	367		
	1400	800	808	832	12.6	17.2	627	498	435	395	380	367		
	1600	900	908	932	13.9	19.0	627	498	435	395	380	367		
	800	950	958	982	14.5	19.9	608	498	435	395	380	367		
	1800	1000	1008	1032	15.2	20.8	577	498	435	395	380	367		
	2000	1100	1108	1132	16.4	22.7	524	498	435	395	380	367		
	1000	1150	1158	1182	17.1	23.6	501	498	435	395	380	367		
	1200	1400	1408	1432	20.3	28.2	412	412	412	395	380	367		
	1400	1600	1608	1632	22.8	31.8	363	363	363	363	363	363		
	1600	1800	1808	1832	25.4	35.5	324	324	324	324	324	324		
	1800	2000	2008	2032	27.9	39.1	294	294	294	294	294	294		
	2000	2200	2208	2232	30.5	42.8	270	270	270	270	270	270		

The indicated load capacity relates to a project working life of 30,000 hours.

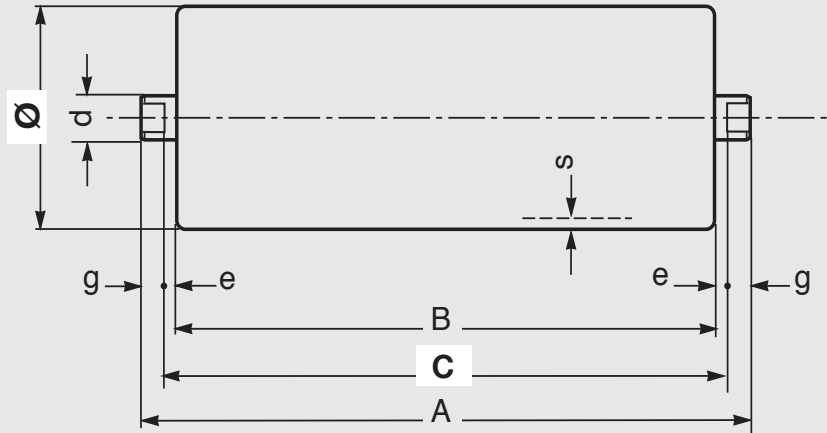
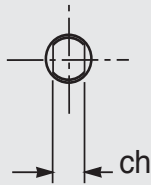

Ø 159 N

Bearing 6306
(30 X 72 X 19)

d = 30
ch = 22
s = 4,5
e = 4
g = 12

Example of ordering
standard design
PSV/5-FHD,30F,159N,1158

for special design
see pages 80-81

belt	roller			weight		load capacity						
	width mm	dimensions mm			Kg	daN						
arrangements 	B	C	A	rotating		belt speed m/s						
				parts	total	1	2	3	4	5	6	
	1000	380	388	412	8.6	10.9	666	528	462	419	389	366
	1200	465	473	497	9.9	12.6	666	528	462	419	389	366
	1400	530	538	562	10.9	14.0	666	528	462	419	389	366
	1000 1600	600	608	632	12.0	15.4	666	528	462	419	389	366
	1800	670	678	702	13.0	16.9	666	528	462	419	389	366
	1200	700	708	732	13.5	17.5	666	528	462	419	389	366
	2000	750	758	782	14.3	18.6	666	528	462	419	389	366
	1400 2200	800	808	832	15.0	19.6	666	528	462	419	389	366
	1600	900	908	932	16.6	21.7	630	528	462	419	389	366
	1800	1000	1008	1032	18.1	23.8	564	528	462	419	389	366
	2000	1100	1108	1132	19.6	25.9	511	511	462	419	389	366
1000		1150	1158	1182	20.4	26.9	488	488	462	419	389	366
	2200	1250	1258	1282	21.9	29.0	449	449	449	419	389	366
1200		1400	1408	1432	24.2	32.1	400	400	400	400	389	366
1400		1600	1608	1632	27.3	36.3	350	350	350	350	350	350
1600		1800	1808	1832	30.4	40.5	311	311	311	311	311	
1800		2000	2008	2032	33.4	44.6	281	281	281	281	281	
2000		2200	2208	2232	36.5	48.8	256	256	256	256		
2200		2500	2508	2532	41.1	55.1	227	227	227	227		

The indicated load capacity relates to a project working life of 30,000 hours.



2 Rollers

series PSV/7-FHD

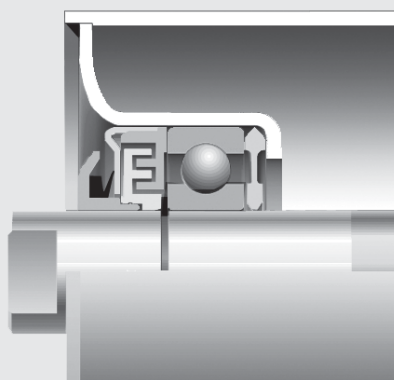

Section through sealing

Ø 108 N

Bearing 6308
(40 X 90 X 23)

d = 40
ch = 32
s = 4
e = 4
g = 12

Example of ordering
standard design
PSV/7-FHD,40F,108N, 473

for special design
see pages 80-81

belt		roller									
width mm	dimensions mm	weight Kg		load capacity daN							
arrangements 	B	C	A	rotating		belt speed m/s					
				parts	total	1	1.5	2	2.5	3	4
1000	380	388	412	7.6	11.6	853	746	677	629	592	538
1200	465	473	497	8.3	13.2	853	746	677	629	592	538
1400	530	538	562	8.9	14.5	853	746	677	629	592	538
1000 1600	600	608	632	9.6	15.8	853	746	677	629	592	538
1800	670	678	702	10.2	17.1	853	746	677	629	592	538
1200	700	708	732	10.5	17.6	853	746	677	629	592	538
2000	750	758	782	10.9	18.6	853	746	677	629	592	538
1400 2200	800	808	832	11.4	19.5	853	746	677	629	592	538
1600	900	908	932	12.3	21.4	853	746	677	629	592	538
1800	1000	1008	1032	13.4	23.4	853	746	677	629	592	538
2000	1100	1108	1132	14.1	25.1	853	746	677	629	592	538
1000	1150	1158	1182	14.5	26.1	853	746	677	629	592	538
2200	1250	1258	1282	15.4	28.0	853	746	677	629	592	538
1200	1400	1408	1432	16.7	30.8	853	746	677	629	592	538
1400	1600	1608	1632	18.5	34.5	743	743	677	629	592	538
1600	1800	1808	1832	20.3	38.3	587	587	587	587	587	538
1800	2000	2008	2032	22.1	42.0	476	476	476	476	476	476
2000	2200	2208	2232	23.9	45.8	393	393	393	393	393	393
2200	2500	2508	2532	26.6	51.4	304	304	304	304	304	304

The indicated load capacity relates to a project working life of 30,000 hours.

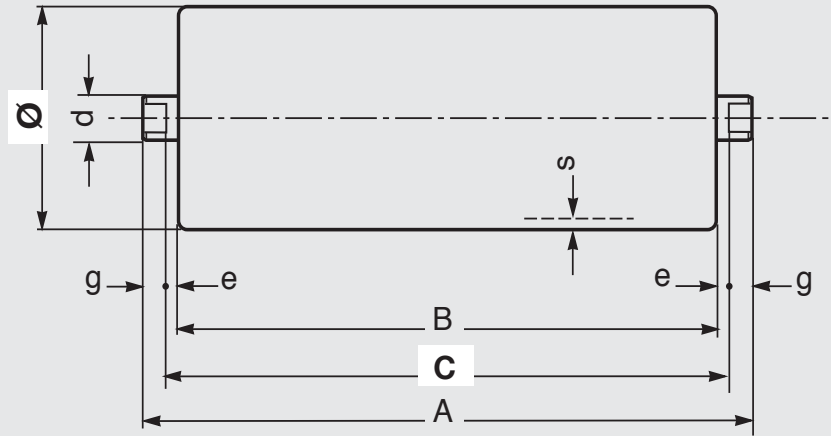
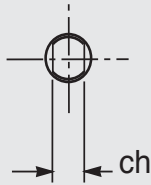

Ø 133 N

Bearing 6308
(40 X 90 X 23)

d = 40
ch = 32
s = 4*
e = 4
g = 12

*s = 6 for basic
rollers with impact
rings

Example of ordering
standard design
PSV/7-FHD,40F,133N,473

for special design
see pages 80-81

belt	roller			weight		load capacity					
	width mm	dimensions mm			Kg	daN					
arrangements 	B	C	A	rotating parts		belt speed m/s					
				parts	total	1	2	3	4	4.5	5
1000	380	388	412	9.3	13.3	915	726	634	576	554	535
1200	465	473	497	10.4	15.2	915	726	634	576	554	535
1400	530	538	562	11.2	16.7	915	726	634	576	554	535
1000 1600	600	608	632	12.1	18.3	915	726	634	576	554	535
1800	670	678	702	13.0	19.9	915	726	634	576	554	535
1200	700	708	732	13.4	20.5	915	726	634	576	554	535
2000	750	758	782	14.0	21.7	915	726	634	576	554	535
1400 2200	800	808	832	14.6	22.8	915	726	634	576	554	535
1600	900	908	932	15.9	25.1	915	726	634	576	554	535
1800	1000	1008	1032	17.2	27.3	915	726	634	576	554	535
2000	1100	1108	1132	18.5	29.6	915	726	634	576	554	535
1000	1150	1158	1182	19.1	30.7	915	726	634	576	554	535
2200	1250	1258	1282	20.4	33.0	915	726	634	576	554	535
1200	1400	1408	1432	22.3	36.3	915	726	634	576	554	535
1400	1600	1608	1632	24.9	40.9	915	726	634	576	554	535
1600	1800	1808	1832	27.4	45.4	915	726	634	576	554	535
1800	2000	2008	2032	30.0	49.9	908	726	634	576	554	535
2000	2200	2208	2232	32.5	54.4	750	726	634	576	554	535
2200	2500	2508	2532	36.4	61.2	581	581	581	576	554	

The indicated load capacity relates to a project working life of 30,000 hours.



2 Rollers

series PSV/7-FHD

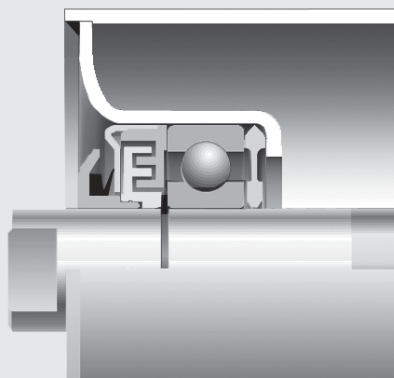

Section through sealing

Ø 159 N

Bearing 6308
(40 X 90 X 23)

d = 40
ch = 32
s = 4,5
e = 4
g = 12

Example of ordering
standard design
PSV/7-FHD,40F,159N,1158

for special design
see pages 80-81

belt	roller										
	width mm	dimensions mm			weight Kg		load capacity daN				
 arrangements	B	C	A	rotating		belt speed m/s					
				parts	total	1	2	3	4	5	6
1000	380	388	412	10.6	14.7	971	771	673	612	568	534
1200	465	473	497	11.9	16.8	971	771	673	612	568	534
1400	530	538	562	12.9	18.4	971	771	673	612	568	534
1000 1600	600	608	632	14.0	20.2	971	771	673	612	568	534
1800	670	678	702	15.1	22.0	971	771	673	612	568	534
1200	700	708	732	15.5	22.7	971	771	673	612	568	534
2000	750	758	782	16.3	24.0	971	771	673	612	568	534
1400 2200	800	808	832	17.1	25.2	971	771	673	612	568	534
1600	900	908	932	18.6	27.7	971	771	673	612	568	534
1800	1000	1008	1032	20.1	30.3	971	771	673	612	568	534
2000	1100	1108	1132	21.7	32.8	971	771	673	612	568	534
1000	1150	1158	1182	22.4	34.0	971	771	673	612	568	534
2200	1250	1258	1282	24.0	36.6	971	771	673	612	568	534
1200	1400	1408	1432	26.3	40.3	971	771	673	612	568	534
1400	1600	1608	1632	29.4	45.4	971	771	673	612	568	534
1600	1800	1808	1832	32.4	50.4	971	771	673	612	568	534
1800	2000	2008	2032	35.5	55.4	922	771	673	612	568	534
2000	2200	2208	2232	38.6	60.5	852	771	673	612	568	534
2200	2500	2508	2532	43.2	68.0	768	768	673	612	568	

The indicated load capacity relates to a project working life of 30,000 hours.

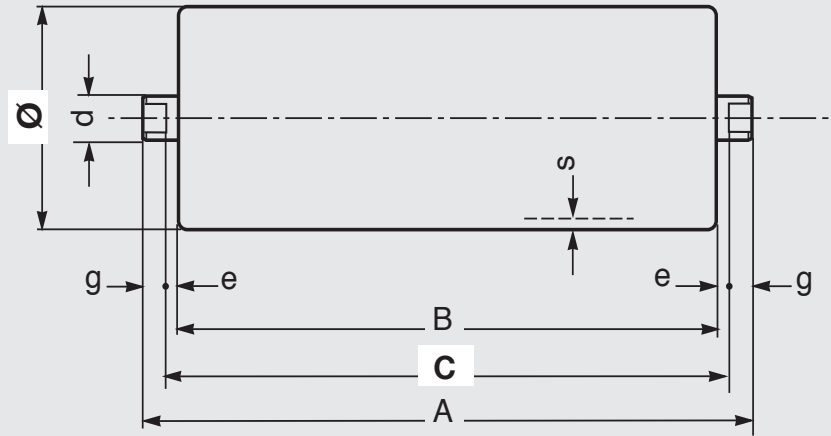
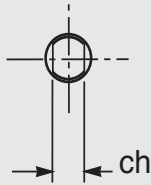

Ø 194 N

Bearing 6308
(40 X 90 X 23)

d = 40
ch = 32
s = 6,3
e = 4
g = 12

Example of ordering
standard design
PSV/7-FHD,40F,194N,758

for special design
see pages 80-81

belt	roller			weight		load capacity						
	width mm	dimensions mm			Kg	daN						
arrangements 	B	C	A	rotating		belt speed m/s						
				parts	total	2	3	4	5	6	7	
	1600	600	608	632	23.2	29.4	823	719	654	607	571	542
	1800	670	678	702	25.2	32.1	823	719	654	607	571	542
	2000	750	758	782	27.6	35.2	823	719	654	607	571	542
	2200	800	808	832	29.0	37.2	823	719	654	607	571	542
	1600 2400	900	908	932	31.9	41.1	823	719	654	607	571	542
	2600	950	958	982	33.4	43.0	823	719	654	607	571	542
	1800	1000	1008	1032	34.9	45.0	823	719	654	607	571	542
	2800	1050	1058	1082	36.3	46.9	823	719	654	607	571	542
	2000	1100	1108	1132	37.8	48.9	823	719	654	607	571	542
	3000	1120	1128	1152	38.4	49.6	823	719	654	607	571	542
	2200	1250	1258	1282	42.1	54.7	823	719	654	607	571	542
	2400	1400	1408	1432	46.5	60.6	823	719	654	607	571	542
	2800	1600	1608	1632	52.3	68.3	823	719	654	607	571	542
	3000	1700	1708	1732	55.3	72.2	823	719	654	607	571	542
	1600	1800	1808	1832	58.2	76.1	823	719	654	607	571	542
	1800	2000	2008	2032	64.0	83.9	823	719	654	607	571	542
	2000	2200	2208	2232	69.8	91.7	760	719	654	607	571	542
	2200	2500	2508	2532	78.6	103.4	672	672	654	607	571	542
	2400	2800	2808	2832	87.3	115.1	605	605	605	605	571	542
	2600	3000	3008	3032	93.2	122.9	567	567	567	567	567	

The indicated load capacity relates to a project working life of 30,000 hours.



2 Rollers

serie PSV/7-FHD

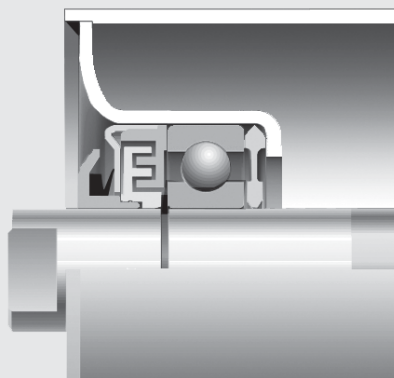

Ø 219 N

Bearing 6308
(40 X 90 X 23)

d = 40
ch = 32
s = 6,3
e = 4
g = 12

Example of ordering
standard design
PSV/7-FHD,40F,219N,1408

for special design
see pages 80-81

belt	roller											
	width mm			dimensions mm		weight Kg		load capacity daN				
arrangements 	rotating parts			total		belt speed m/s						
	B	C	A	3	4	5	6	7	8			
1600	600	608	632	25.0	31.2	749	681	632	595	565	540	
1800	670	678	702	27.3	34.2	749	681	632	595	565	540	
2000	750	758	782	30.0	37.6	749	681	632	595	565	540	
2200	850	858	882	33.2	41.9	749	681	632	595	565	540	
1600 2400	900	908	932	34.9	44.0	749	681	632	595	565	540	
2600	950	958	982	36.5	46.2	749	681	632	595	565	540	
1800	1000	1008	1032	38.2	48.3	749	681	632	595	565	540	
2800	1050	1058	1082	39.8	50.4	749	681	632	595	565	540	
2000	1100	1108	1132	41.5	52.6	749	681	632	595	565	540	
3000	1120	1128	1152	42.1	53.4	749	681	632	595	565	540	
2200	1250	1258	1282	46.4	58.9	749	681	632	595	565	540	
2400	1400	1408	1432	51.3	65.3	749	681	632	595	565	540	
2800	1600	1608	1632	57.9	73.9	749	681	632	595	565	540	
3000	1700	1708	1732	61.2	78.1	749	681	632	595	565	540	
1600	1800	1808	1832	64.4	82.4	749	681	632	595	565	540	
1800	2000	2008	2032	71.0	90.9	695	681	632	595	565	540	
2000	2200	2208	2232	77.6	99.5	632	632	632	595	565	540	
2200	2500	2508	2532	87.4	112.2	556	556	556	556	556	540	
2400	2800	2808	2832	97.3	125.0	498	498	498	498	498	498	
2600	3000	3008	3032	103.8	133.6	465	465	465	465	465	465	
2800	3150	3158	3182	108.8	140.0	444	444	444	444	444	444	
3000	3350	3358	3382	115.3	148.5	418	418	418	418	418	418	

The indicated load capacity relates to a project working life of 30,000 hours.

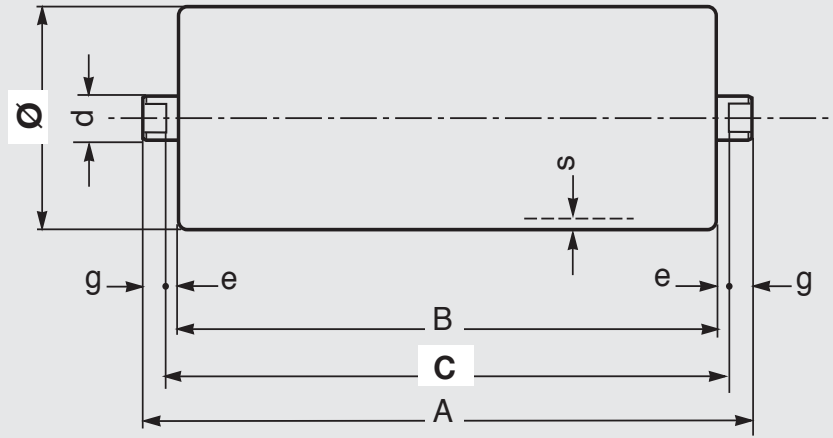
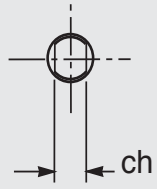

2 Rollers

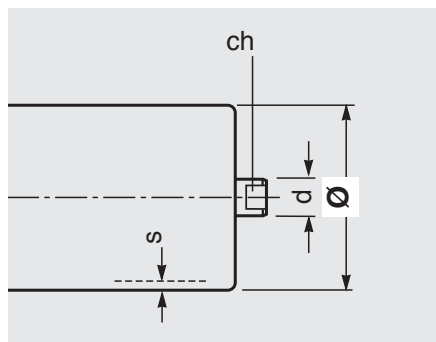

The table indicates rollers with non standard diameters that we are already producing.

Upon request rollers may be supplied with varying dimensions, tube thickness and diameters according to standards CEMA, BS, JIS, AFNOR and ISO-FEM .

Production programme of non standard PSV on request

roller type	Ø basic		s	splinde		bearing	notes	
	mm	design		d	ch			
PSV/1-FHD	76	N	3	20	14	6204	with tube and spindle in steel S235JR (EN 10027-1) ex Fe360 (EN 10025) St37 (DIN 17100)	
	102	N	3					
	114	N	3,5					
	127	N	4					
	140	N	4					
PSV/2-FHD	76	N	3	25	18	6205		with tube and spindle in steel S235JR (EN 10027-1) ex Fe360 (EN 10025) St37 (DIN 17100)
	102	N	3					
	114	N	3,5					
	127	N	4					
	140	N	4					
	168	N	4,5					
PSV/3-FHD	102	N	3	25	18	6305	with tube and spindle in steel S235JR (EN 10027-1) ex Fe360 (EN 10025) St37 (DIN 17100)	
	127	N	4					
	140	N	4					
	152	N	4					
	168	N	4,5					
PSV/4-FHD	102	N	3	30	22	6206		with tube and spindle in steel S235JR (EN 10027-1) ex Fe360 (EN 10025) St37 (DIN 17100)
	127	N	4					
	140	N	4					
	152	N	4					
	168	N	4,5					
PSV/5-FHD	140	N	4	30	22	6306	with tube and spindle in steel S235JR (EN 10027-1) ex Fe360 (EN 10025) St37 (DIN 17100)	
PSV/7-FHD	127	N	4	40	32	6308		
	152	N	4					
	178	N	6,3					